

TECHNICAL MANUAL

**OPERATORS, ORGANIZATIONAL,
DS, GS, AND DEPOT MAINTENANCE MANUAL
INCLUDING REPAIR PARTS AND SPECIAL TOOLS LISTS**

**CAMERA SET,
STILL PICTURE
KS-99B**

HEADQUARTERS, DEPARTMENT OF THE ARMY

JUNE 1970

CHANGE }
 No. 1 }

HEADQUARTERS
 DEPARTMENT OF THE ARMY
 WASHINGTON, D. C., 25 July 1974

**Operator's, Organizational, Direct Support,
 General Support, and Depot Maintenance Manual
 Including Repair Parts and Special Tools Lists**

**CAMERA SET,
 STILL PICTURE
 KS-99B**

TM 11-6720-243-15, 10 June 1970, is changed as follows:

1. A vertical bar appears opposite changed material.
2. Remove and insert pages as indicated in the page list below:

<i>Remove pages</i>	<i>Insert pages</i>
<i>i and 1-0</i>	<i>i</i>
<i>None</i>	<i>1-0</i>
<i>1-1 and 1-2</i>	<i>1-1, 1-2 and 1-2.1</i>
<i>2-1 and 2-2</i>	<i>2-1 and 2-2</i>
<i>B-1 through B-3</i>	<i>B-1 through B-3</i>

3. File this change sheet in front of the manual for reference purposes.

By Order of the Secretary of the Army:

Official:

VERNE L. BOWERS
Major General, United States Army
The Adjutant General

CREIGHTON W. ABRAMS
General, United States Army
Chief of Staff

TM 11-6720-243-15

Distribution:

Active Amy:

USASA (2)
CNGB (1)
Dir of Trans (1)
COE (1)
TSG (1)
USAARENBD (1)
USAMB (10)
AMC (1)
TRADOC (2)
ARADCOM (2)
ARADCOM Rgn (2)
OS Maj Comd (4)
LOGCOMDS (3)
MICOM (2)
TECOM (2)
USACC (4)
MDW (1)
Armies (2)
Corps (2)
HISA Ft Monmouth (18)
Svc Colleges (1)
USASESS (5)
USAADS (2)
USAFAS (2)
USAARMS (2)
USAIS (2)
USAES (2)
USAINTCS (3)

WRAMC (1)
ATS (1)
Fort Gordon (10)
Fort Huachuca (10)
Fort Carson (5)
Ft Richardson (ECOM Ofc) (2)
Army Dep (1) except
LBAD (14)
SAAD (30)
TOAD (14)
ATAD (10)
USA Dep (2)
Sig Sec USA Dep (2)
Sig Dep (2)
Sig FLDMS (1)
USAERDAA (1)
USAERDAW (1)
MAAG (1)
USARMIS (1)
Units org under fol TOE:
(1 copy each)
11-96
11-97
11-98
11-117
11-127
11-500 AA-AC
WSMR (1)

NR: None

USAR: None

For explanation of abbreviations used, see AR 310-50.

This publication contains copyrighted material. Permission for its use in this manual has been granted by Charles Bessler Company, 219 South 18th Street, East Orange, N.J.

TM 11-6720-243-15

TECHNICAL MANUAL }
 No. 11-6720-243-15 }

HEADQUARTERS
 DEPARTMENT OF THE ARMY
 WASHINGTON, D. C., 10 June 1970

**OPERATOR'S ORGANIZATIONAL, DIRECT SUPPORT, GENERAL SUPPORT AND DEPOT
 MAINTENANCE MANUAL INCLUDING REPAIR PARTS AND SPECIAL TOOLS LISTS**

CAMERA SET, STILL PICTURE KS-99B

		Paragraph	Page
CHAPTER 1.	INTRODUCTION		
Section I.	General	1-1	1-1
II.	Description and data	1-4	1-1
III.	Camera accessories	1-13	1-3
CHAPTER 2.	SERVICE UPON RECEIPT OF EQUIPMENT	2-1	2-1
3.	OPERATING INSTRUCTIONS		
Section I.	Operator's controls and indicators	3-1	3-1
II.	Preliminary procedures	3-3	3-6
III.	Operation under usual conditions	3-8	3-11
IV.	Operation under unusual conditions	3-13	3-17
CHAPTER 4.	OPERATOR'S MAINTENANCE INSTRUCTIONS	4-1	4-1
5.	ORGANIZATIONAL MAINTENANCE INSTRUCTIONS	5-1	5-1
6.	SHIPMENT AND LIMITED STORAGE AND DEMOLITION TO PREVENT ENEMY USE		
Section I.	Shipment and limited storage	6-1	6-1
II.	Demolition of materiel to prevent enemy use	6-3	6-1
APPENDIX A.	REFERENCES		A-1
B.	BASIC ISSUE ITEMS LIST (BIIL) AND ITEMS TROOP INSTALLED OR AUTHORIZED LIST (ITIAL)		B-1
C.	MAINTENANCE ALLOCATION		C-1
D.	REPAIR PARTS FOR ORGANIZATIONAL, DS, GS, AND DEPOT MAINTENANCE		D-1
INDEX		I-1

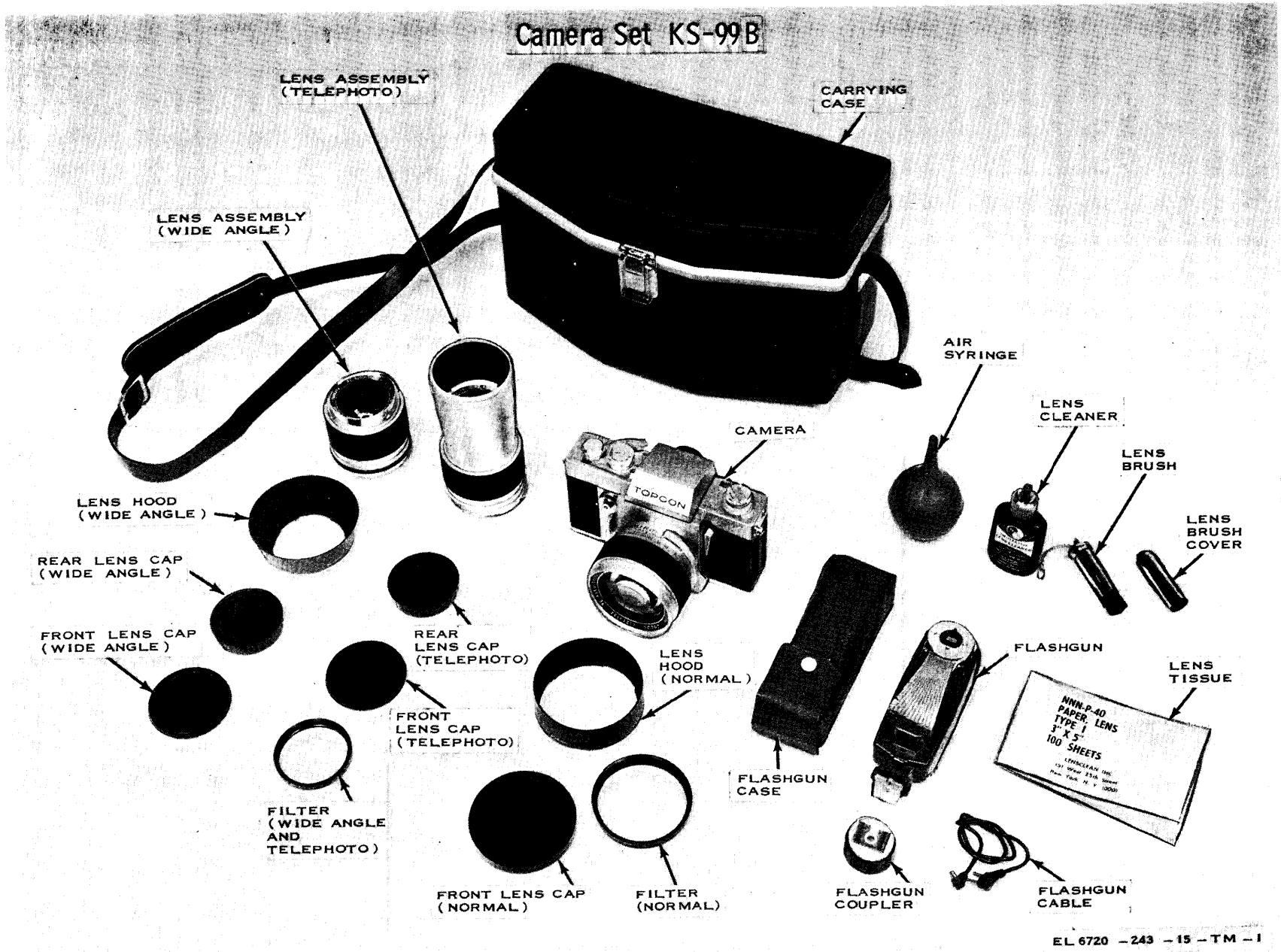

Figure 1-1. Camera Set, Still Picture KS-99B.

CHAPTER 1 INTRODUCTION

Section I GENERAL

1-1. Scope

a. This manual describes Camera Set, Still Picture KS-99B (camera set) (fig. 1-1) and covers its installation, operation, and operator's preventive maintenance. It includes operation under usual and unusual conditions, cleaning and inspection of the equipment, and replacement of parts available to the operator. It also includes mechanical and electrical performance checks.

b. Appendixes B, C, and D are current as of 5 February 1970.

1-2. Indexes of Publications

a. *DA Pam 310-4.* Refer to DA Pam 310-4 to determine whether there are new editions, changes, or additional publications pertaining to the equipment.

b. *DA Pam 310-7.* Refer to DA Pam 310-7 to determine whether there are modification work orders (MWO'S) pertaining to the equipment.

1-3. Forms and Records

a. *Report of Maintenance and Unsatisfactory Equipment.* Use equipment forms and records in accordance with instructions given in TM 38-750.

b. *Report of Packaging and Handling Deficiencies.* Fill out and forward DD Form 6 (Report of Packaging and Handling Deficiencies) as prescribed in AR 700-58/NAVSUP PUB 378/AFR 71-4/MCO P4030.29, and DSAR 4145.8.

c. *Discrepancy in Shipment Report (DISREP) (SF 361).* Fill out and forward Discrepancy in Shipment Report (DISREP) (SF 361) as prescribed in AR 55-38/NAVSUPINST 4610.33/AFM 75-18/MCO P4610. 19A, and DSAR 4500.15.

d. *Reporting of Equipment Manual Improvements.* The reporting of errors, omissions, and recommendations for improving this publication by the individual user is encouraged. Reports should be submitted on DA Form 2028 (Recommended Changes to Publications and Blank Forms) am-1 forwarded direct to Commander, US Army Electronics Command, ATTN: AMSEL-MA-S, Fort Monmouth, NJ 07703.

Section II. DESCRIPTION AND DATA

1-4. Purpose and Use

a. *Purpose.* Camera Set, Still Picture KS-99B is a single lens reflex 35-millimeter (mm), self-contained, portable, hand-operated, camera equipment.

b. *Use.* The camera set is used in the field to make black and white or color photographs. The camera set can be used under extreme lighting conditions and is supplied with lenses of various focal lengths for specific applications.

1-5. Technical Characteristics

Camera Still picture, general purpose, single lens, reflex camera.
Shutter data:
Type Focal plane shutter, with non-rotating single axle shutter speed dial.

Speed setting 1, 1/2, 1/4, 1/8, 1/15, 1/30, 1/60, 1/125, 1/250, 1/500, and 1/1000 sec plus bulb (B); internally coupled built-in exposure meter.
Flash synchronization Automatic internal peak compensating flash synchronization, with single flash socket for all flash bulbs and electronic flash units. Built-in accidental flash prevention double contact system.
Self timer Adjustable for 5- to 10-second delayed action.
Finder assembly date:
Type Optical, through the lens.
Focusing screen Ground glass with split-image rangefinder spot surrounded by fine focus ring (interchangeable).
Image erection Eye-level pentaprism finder interchangeable with waist level finders.

TM 11-6720-243-15

Depth of field preview Push-release lever to stop lens
 clown for depth of field pre-
 view.

Exposure control:
 Type Automatic (Cds) meter type
 with ON-OFF switch.

Cell location Behind mirror.

Battery 1.3-volt Everready No. 625, or
 equal.

Film accommodated:
 Type 35 mm, double perforated,
 black and white, color or in-
 frared.

Format size 24 mm by 36 mm.

Capacity 20 or 36 exposures in daylight-
 loading cartridge.

Lens data:

a. *Normal Lens.*
 Type 7 elements.
 Focal length 58 mm.
 Focusing range 18 inches to infinity.
 Aperture stops f/1.4, 2.2, 8, 4.5, 6.8, 11, 16.

b. *Telephoto Lens.*
 Type 6 elements.
 Focal length 135 mm.
 Focusing range 5 ft to infinity.
 Aperture stops f/3.5, 5.6, 8, 11, 16, 22.

c. *Wide-Angle Lens.*
 Type 5 elements.
 Focal length 35 mm.
 Focusing range 9 inches to infinity.
 Aperture stops f/2.8, 4.5, 6.8, 11, 16, 22.

1-6. Items Comprising an Operable Equipment

Qty.	Nomenclature, part No., and mfr code	Fig. No.	Height	Dimensions(in.).		Length	Weight
				Width			
NOTE							
The part number is followed by the applicable 5-digit Federal supply code for manufacturers (FSCM) identified in SB 708-42 and used to identify manufacturer, distributor, or Government agency, etc.							
6720-935-3860	Camera Set, Still Picture KS-99B consisting of:	1-1	—	—	—	—	—
6720-484-0930	Camera, Still Picture KE-53A	1-1	4	5 1/2	3 11/16		1 lb, 8 oz
6760-487-4134	1 Adapter, Shoe Flash BT-69;	1-1	1 1/2	13/4 (dia)	—		4 oz
6760-486-8328	1 Filter, Light Photographic Lens:	1-1	2 1/2	—	3/8		2 oz
6760-832-4757	1 Filter, Light Photographic Lens: BT-73-Y2; (07055)	1-1	2	—	5/16		1 oz
6760-937-9968	1 Flash Gun Photographic BT-220; (07055)	1-1	1 1/2	1 3/4	5 1/2		6 oz
6760-487-4136	1 Lens, Camera, General Photographic BT-335; (07055)	1-1	—	—	—		—
6760-487-4137	1 Lens, Camera, General Photographic BT-375; (07055)	1-1	—	—	—		—
6760-485-9701	1 Lens Hood: BT-17C; (07055)	1-1		2 3/4	1 1/16		1 oz
6760-485-9702	1 Lens Hood: BT-53; (07055)	1-1		3 (dia)	1 1/2		2oz

1-6.1. Expendable Consumable Supplies and Equipment

Expendable consumable supplies and material are listed in table 1-1.

Table 1-1. Expendable Consumable Supplies and Material

The supplies and material listed in this table are required for operation of this equipment and are authorized to be requisitioned by SB 700-50. The FSN for the applicable unit of issue required can be found in appropriate supply catalogs. The FSCM is used as an element in item identification to designate manufacturer or distributor or Government agency, etc., and is identified in SB 708-42.

<i>Item</i>	<i>Description</i>	<i>Ref No. and FSCM</i>	<i>FSC</i>
1	Cleaner, Lens:	04217 (06650)	7930
2	Tissue Lens:	Mil-P-40 Type 1; (96906)	6640

1-7. Description of Camera Set
(fig. 1-1)

The camera set includes four major components and various minor components. The major components consist of (including its normal lens assem-

bly), a camera, two additional lens assemblies (telephoto and wide-angle), and a flashgun. The minor components consist of two filters, two lens hoods, five lens caps, an air syringe, a lens brush, a package of lens tissue, a bottle of lens cleaner and a fitted carrying case.

1-8. Description of Camera

(figs. 3-1, 3-2, and 3-3)

The camera is a hand-held, 35-mm, single-lens, reflex-type focal plane shutter camera equipped with a normal (f/1.4 58 mm 7 element) lens assembly. The camera body has provisions for accepting interchangeable lens with Exakta-type modified bayonet mounts and will accommodate telephoto and wide-angle lens assemblies. Focusing is accomplished through the lens by a mirror, the split-image focusing screen, and the pentaprism finder. Exposure control is manually controlled by the operator with the aid of a built-in behind-the-mirror cadmium sulphide average reading exposure meter and a match-point indicator (fig. 3-11). The hinged cover at the back of

the camera facilitates film loading and resets the film counter after loading. The camera has a built-in shutter release delay mechanism and provisions for electronic flash and flashbulb synchronization. The film-winding level, on the top of the camera, simultaneously advances the film and cocks the shutter. The focal plane shutter speed and film speed setting are set by individual film speed adjusting rings on the top of the camera (fig. 3-2). Battery BA-261/U, on the base of the camera, provides power to operate the exposure metering system. The shutter release button is on the front of the camera. The bottom of the camera contains the tripod socket, the rewind button, the motor drive shaft, the exposure meter control switch, the battery compartment and the back cover lock release (fig. 3-3).

1-9. Description of Flashgun

The flashgun (fig. 3-4 and 3-5) consists of a self-contained, folding reflector assembly, a housing assembly, and a flashgun cable. The flashgun is especially designed for use with the camera, with electrical connections made directly with flash terminal when the flashgun is inserted in the flashgun coupler attached over the rewind knob of the camera, or by a flashgun cable when the flashgun is used off the camera. The housing assembly houses the battery, a capacitor, and an associate circuit that supplies the power to fire the flashbulbs. The flashgun has a circuit test indicator lamp and a flash bulb ejector. The lamp socket accommodates bayonet (No. 5), miniature bayonet (M2), and all glass (AG-1) base flashbulbs.

1-10. Description of Telephoto Lens

The telephoto lens is a fully automatic instant-opening, diaphragm action f/3.5 135-mm lens covering an 180 field of view with a minimum focus-

ing distance of 5 feet. A collapsible lens hood is also part of the lens itself.

1-11. Description of Wide-Angle Lens

The wide-angle lens is a fully automatic, instant-opening, diaphragm action f/2.8 35-mm lens covering a 630 field of view with a minimum focusing distance of 9 inches.

1-12. Description of Minor Components

(fig. 1-1)

a. Carrying Case. The carrying case is a fitted case which has compartments for all parts of the camera set. The carrying case has a shoulder strap and locking device.

b. Lens Hoods. The normal and wide lens hoods are attached to the front outside bayonet mount of their respective lenses. The telephoto lens hood is collapsible and is part of the lens itself; it is pulled out for use and pushed back when not required.

c. Filters. The filters are optical glass colored disks which are fitted in a threaded mount. The threaded mount can be screwed into the front of the lenses.

d. Air Syringe, Lens Brush, Lens Cleaner, and Lens Tissue. The air syringe, lens brush, lens cleaner, and lens tissue are used to clean the optical surface of the camera set.

e. Lens Caps. Front and rear lens caps are provided the telephoto and wide-angle lens assemblies; only a front lens cap is provided for the normal lens assembly.

f. Flashgun Coupler. The flashgun coupler attaches to the camera body and provides the mechanical means of attaching the flashgun on the camera. The accessory shoe on top of the flashgun coupler accepts the mounting foot of the flashgun.

Section III. CAMERA ACCESSORIES

1-13. General

The accessories required for photomacrography (fig. 1-2) are not part of the camera set and must be requisitioned separately. A high magnification waist level finder and the suitable interchangeable focusing screen are recommended for maximum performance in photomacrography (fig. 1-3).

1-14. High Magnification Waist Level Finder

(fig. 1-3)

The high magnification waist level finder is a re-

flex-type finder incorporating a high magnification power wide-angle magnifying optic system of four lens elements in three groups. When attached to the camera, in place of the standard pentaprism finder, it shows the full focusing screen enlarged 6.5x and is especially valuable for critical focusing in photomacrography. The eyepiece is adjustable and permits dioptic adjustments within the range from -3 to +2. The image is reversed laterally, and with the normal 58-mm lens the image is enlarged 1.5x. When the high

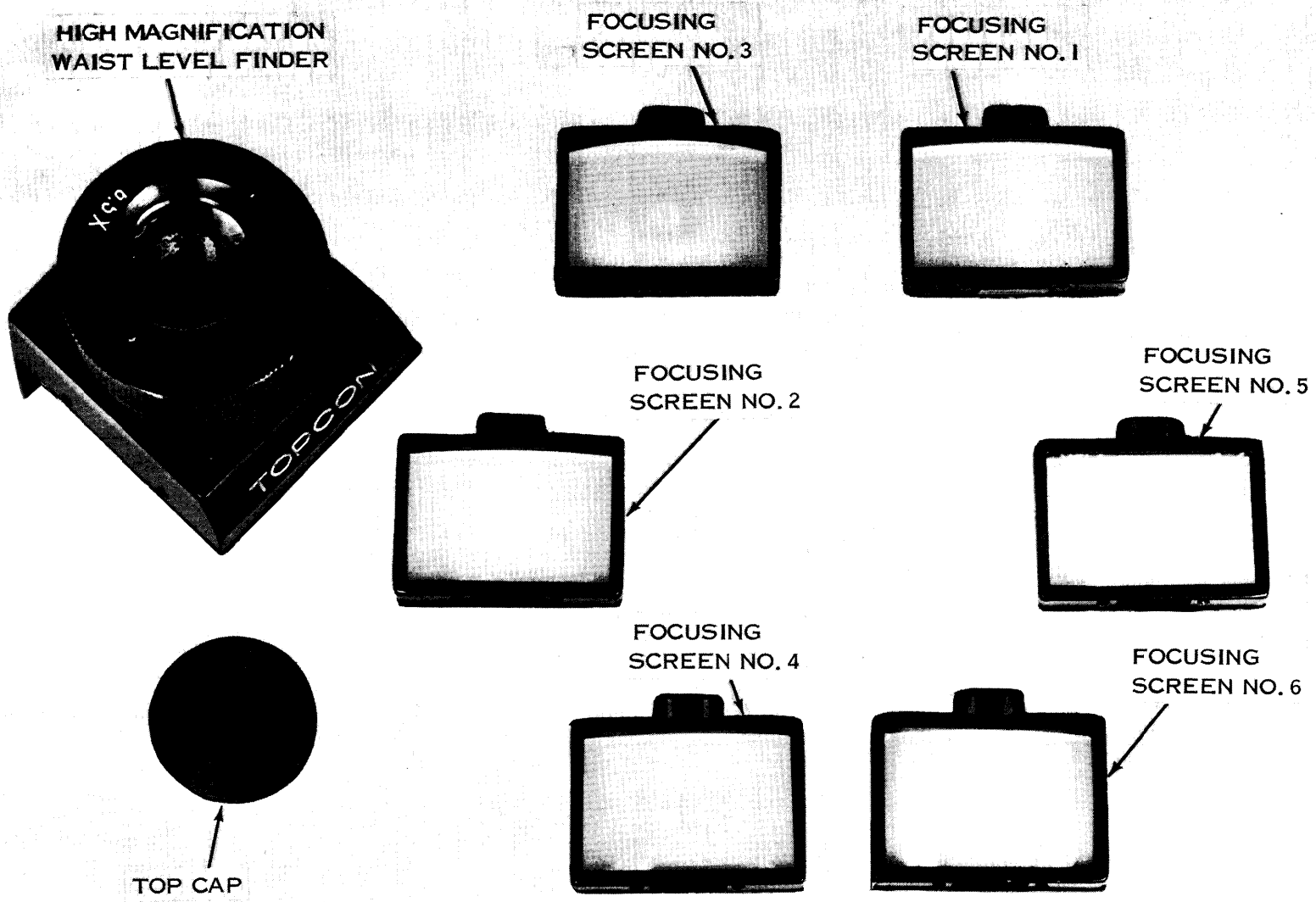

EL 6720-243-15-TM-2

Figure 1-2. Camera accessories for photomacrography.

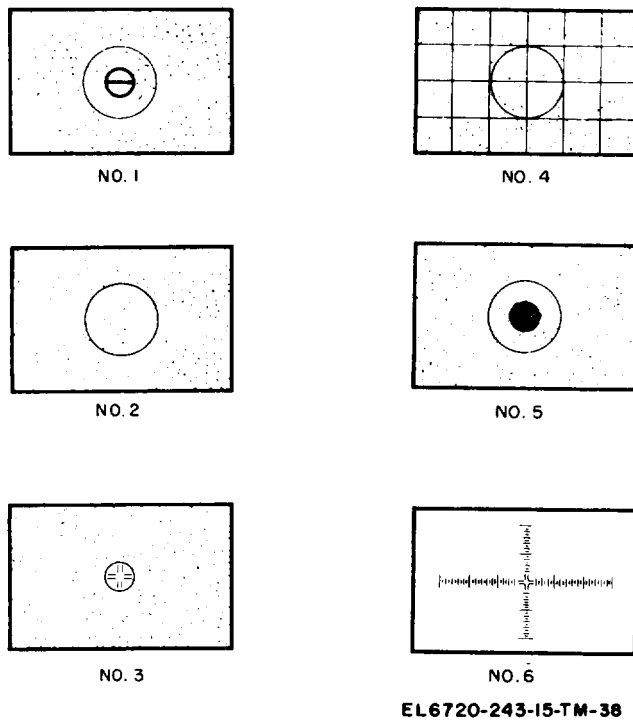

EL6720-243-15-TM-38

Figure 1-3. Interchangeable focusing screen

magnification waist level finder is attached to the camera, the exposure indicator in the pentaprism finder cannot be used. The exposure indicator on the deck, next to the finder (fig. 3-2), must be used for setting the correct exposure. The eyepiece must be covered with the top cap when an exposure reading is taken to prevent extraneous light from entering, and causing a wrong exposure reading.

1-15. Focusing Screens

The chart below gives the description and recommended use of the focusing screens. Focusing screen type No. 1 is standard equipment on the camera. The appearance of each type of focusing screen is shown in figure 1-2.

Topcon interchangeable focusing screens			
Type	Designation	Surface	Featured
No. 1 - - -	Split-image rangefinder - - - - -	3-mm diameter split-image rangefinder spot surrounded by ground glass ring, and ground glass plus fresnel outside 12-mm diameter central area.	Recommended for general use. Speedy and accurate focusing is possible with central split-image rangefinder. Ground glass focusing is recommended for f/8 and smaller lens openings, and in microphotography, because of blackout of one of prism halves.
No. 2 - - -	Ground glass - - - - -	Full area ground glass plus fresnel lens outside central 12-mm diameter spot.	Recommended for general use for those who prefer to focus with ground glass; or for closeups, copying work; longer lenses, etc, when small lens openings are the rule.
No. 3 - - -	Crosshairs - - - - -	5-mm diameter clear spot in center with double crosshairs, plus ground glass outside 5-mm dia area.	Recommended for: photomacrography and astrophotography; for focusing of aerial image, when subject grows rather dark as image magnification increases, by eliminating parallax between crosshairs and image and/or adjusting eyepiece to user's eyesight with crosshairs and then focusing. Focusing is possible with ground glass area.
No. 4 - - -	Checkerboard - - - - -	Full area ground glass plus fresnel lens outside 12-mm diameter spot, with horizontal and vertical lines etched at 5-mm intervals.	Same screen as No. 2 plus checkerboard etched lines, especially valuable for focusing plus control in subject placement and alignment of straight lines. Recommended for architectural and interior photography, plus closeups and copying work.

TM 11-6720-243-15

Topcon interchangeable focusing screens			
<i>Type</i>	<i>Designation</i>	<i>Surface</i>	<i>Features</i>
No. 5- - - - -	Microprism focusing - - - - -	5-mm diameter microprism focusing spot surrounded by ground glass ring, and ground glass plus fresnel lens outside 12-mm diameter area.	Recommended for general photography because it splits up image in all directions and does not require searching for a line to split. Central grid spot may darken at lens openings smaller than f/5.6.
No. 6- - - - -	Crosshairs with cross scales - - - -	Clear screen with bisecting scales engraved for 0.5-mm division and central double crosshairs measuring 3 mm x 3 mm.	Specially recommended for photography with microscope, with focusing of serial image or by checking parallax, as with No. 3 screen; should be used in combination with special accessory magnifier. Clear glass screen without fresnel lens.

CHAPTER 2

SERVICE UPON RECEIPT OF EQUIPMENT

2-1. Unpacking

(fig. 2-1)

a. Packaging and Packing Data. For domestic shipment, the camera set is packed and shipped in two (nested) corrugated fiberboard cartons. The inner carton is wrapped and sealed in a moisture-vaporproof barrier. The outer carton is sealed with sealing tape.

b. Unpacking Camera Set. Unpack the camera set as follows:

CAUTION

Avoid thrusting sharp tools into the interior of the corrugated, fiberboard cartons; the camera set may become damaged.

(1) Slit the sealing tape that seals the seam of the outer corrugated, fiberboard carton; lift out the camera set packed in the moisture-vaporproof barrier.

(2) Slit the seam of the moistureproof bar-

rier; lift out the inner corrugated, fiberboard carton.

(3) Carefully slit the sealing tape on the inner corrugated, fiberboard carton; open the flaps, and lift out the carrying case which contains the camera and the flashgun.

(4) Open the carrying case and remove any packing material which is used to cushion the camera set components.

2-2. Checking Unpacked Equipment

a. General.

(1) Inspect the camera set components (fig. 1-1) for damage which may have been incurred during shipment. If the equipment has been damaged, report the damage on DD Form 6 (para 1-2 b).

(2) Check to see that the equipment is complete as listed on the packing slip. If a packing slip is not available, check the equipment against

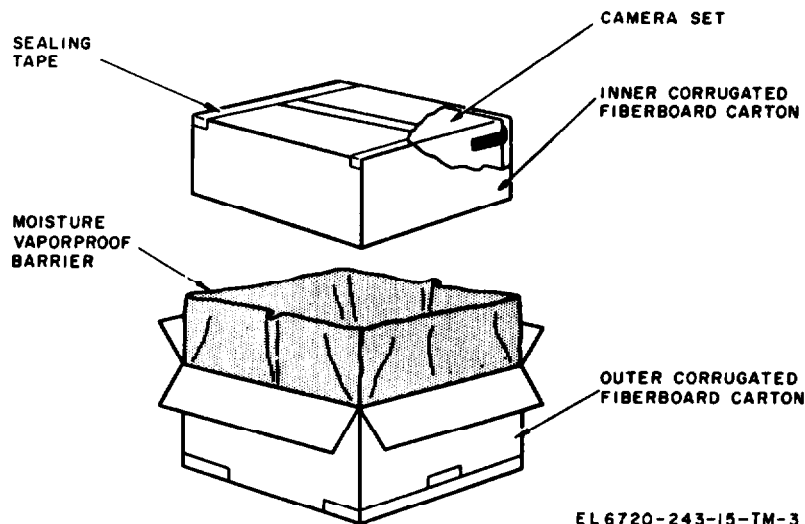

EL 6720-243-15-TM-3

Figure 2-1. Camera set, typical packaging diagram.

the items comprising an operable equipment (para 1-6). Report all discrepancies on DA Form 6.

NOTE

Shortage of a minor component that does not affect proper functioning of the equipment should not prevent use of the camera set.

(3) If the camera has been used or reconditioned, check to see whether it has been changed by a modification work order. If the equipment has been modified, the MWO number will appear on the equipment. Check to see whether the MWO number (if any) and appropriate notations concerning the modification have been entered in the equipment manual.

NOTE

Current MWO'S applicable to the equipment are listed in DA Pam 310-7.

(4) Check to see that the mechanical and optical parts of the camera set are clean. If necessary, clean the camera set.

b. Camera.

(1) Check the normal lens assembly and the optical parts on the camera body for cracked, loose, or damaged parts.

(2) Check the camera body for loose or damaged controls and indicators.

(3) Open the hinged back cover of the camera; check to see that it swings open without binding.

(4) Check the film sprockets, the takeup spool, the film pressure plate, and the hinged back cover for damaged or missing parts.

(5) Check the film winding lever and the rewind knob for proper action.

(6) Remove and install the normal lens assembly to check the operation of the bayonet lens mount and lock.

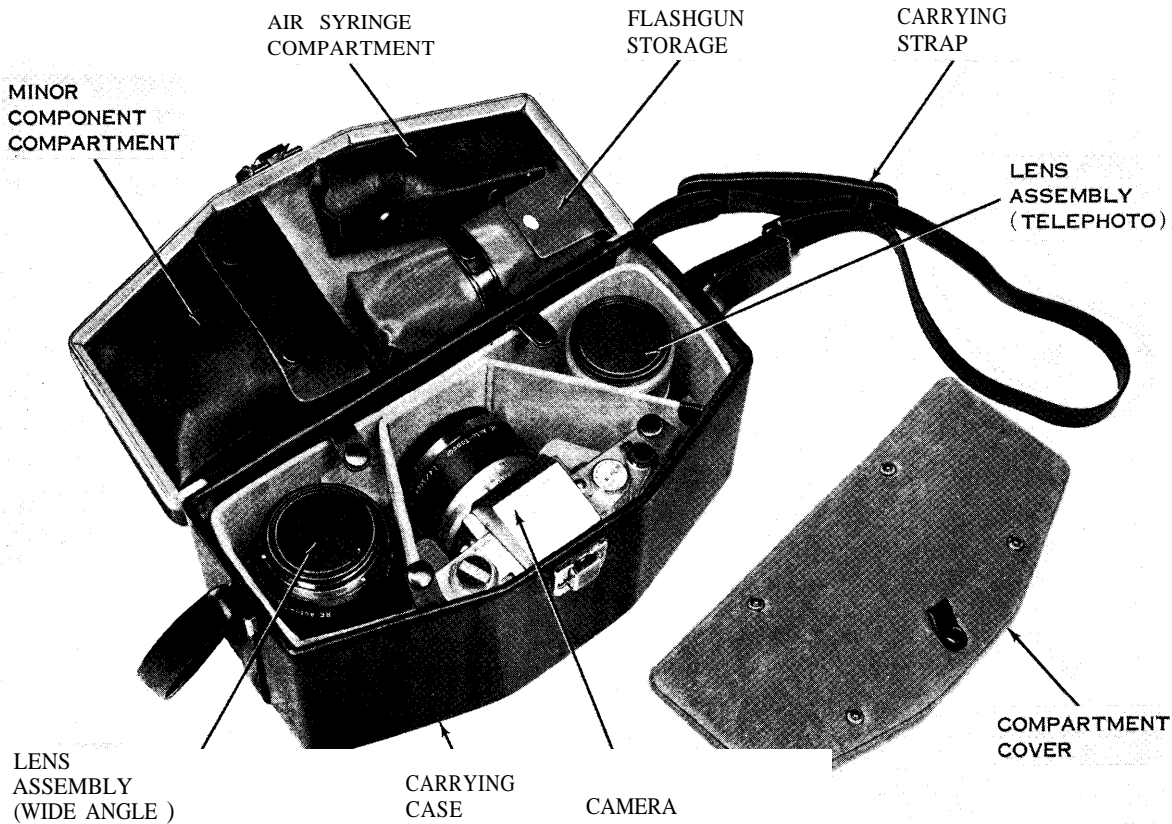

EL 6720 -243 -15 -TM -4

Figure 2-2. Camera set components stored in carrying case.

(7) Check the general condition of the camera body and the lens assembly mounted on the camera body.

c. Flashgun.

(1) Check the folding reflector assembly and the housing assembly for broken or cracked parts.

(2) Check the flashgun cable for damaged flash connector and plug, and wear, fraying, or abrasions of the cable.

(3) Check the battery and the capacitor for cleanliness and proper installation.

(4) Check the tightness of the mounting foot, and for smooth operation of the locking knob.

d. Flashgun Mounting. Check the mounting and connection of the flashgun on the camera as follows :

(1) After checking the flashgun (c above), install the flashgun on the camera.

(2) Check to see that the flashgun is held firmly in place by the locking knob.

(3) Check to see that the connectors on the ends of the flashgun cable fit snugly in their respective outlets.

(4) Disconnect the flashgun cable, and remove the flashgun from the camera.

(5) Fold up the folding reflector assembly, and return the flashgun and the flashgun cable to the flashgun case; store the assembled parts in the flashgun storage area in the carrying case cover (fig. 2-2).

e. Lens A Assemblies and Minor Components.

(1) Check the optical surfaces of the wide-angle and telephoto lens assemblies for damage, scratches, and dirt.

(2) Check the lens assemblies controls for proper operation, and the exterior surfaces for dirty, bent, cracked, or damaged surfaces.

(3) Check the screw threads on the filter and the lens hood for damage.

(4) Check the remaining minor components for damage, cleanliness, smoothness of operation, and quantity.

(5) Return the inspected lens assemblies and the minor components to their respective compartments in the carrying case for storage until they are needed (fig. 2-2).

**CHAPTER 3
OPERATING INSTRUCTIONS**

Section I. OPERATOR'S CONTROLS AND INDICATORS

3-1. Camera Controls and Indicators

a. *Camera Controls.* The chart below lists the

camera controls used by the operator and describes their function.

<i>Control</i>	<i>Function</i>
Aperture ring adjustment control (fig. 3-2) -----	Facilitates movement of aperture ring for setting diaphragm of lens assembly.
Back cover lock release (fig. 3-3) -----	Releases back cover to permit access to film.
Cable release socket (fig. 3-1) -----	Permits attachment of cable release to shutter for remote tripping of shutter mechanism.
Depth of field preview lever (fig. 3-1) -----	Permits actual previewing of depth of field for predetermined aperture.
Film speed adjusting ring (fig. 3-2)-----	Spring-loaded, two-position control.
	<i>Position</i> <i>Action</i>
	Up----- Facilitates setting ASA film speed in ASA film indicator window.
	Down (normal) ---- Facilitates setting of shutter speed.
Film winding lever (fig. 3-1)-----	Advances film one frame, cocks shutter, and advances exposure counter scale and division.

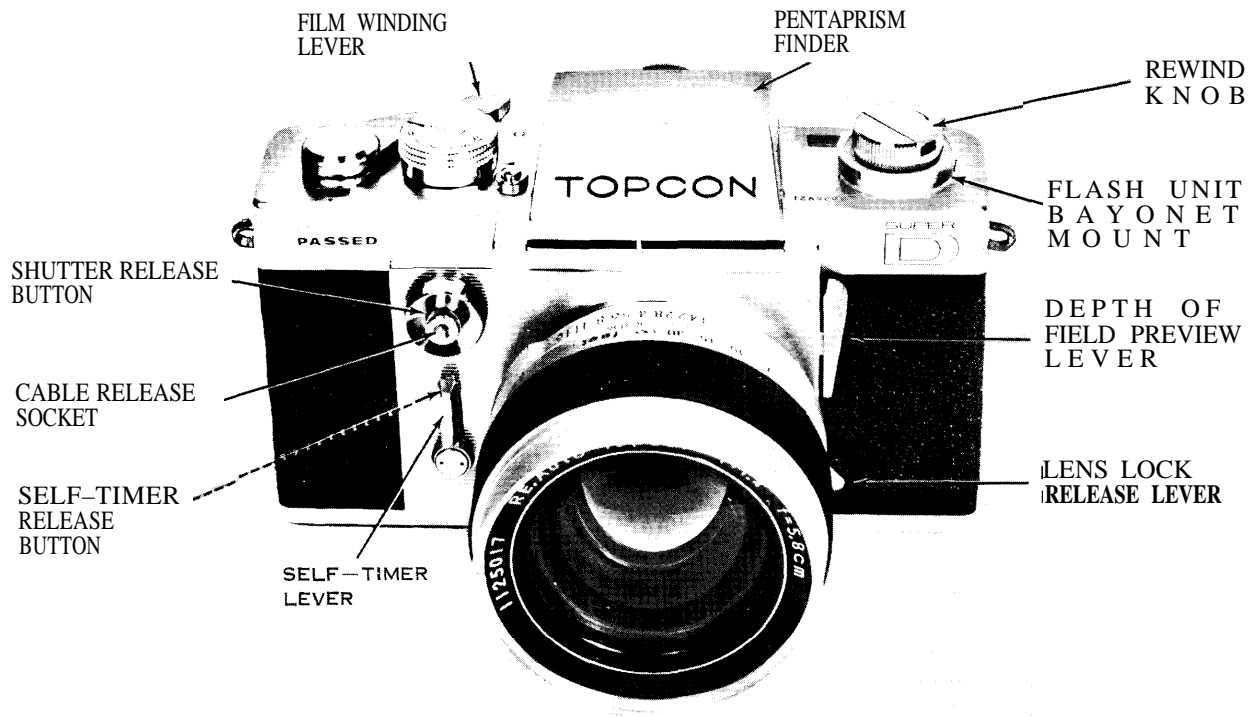

EL-6720-243-15 -TM -5

Figure 3-1. Camera controls and indicators, front view.

<i>Control</i>	<i>Function</i>
Flash socket (fig. 3-2)-----	Extends internal shutter synchronization contacts outside of camera; permits connection of flash unit cable to camera,
Focusing ring (fig. 3-2)-----	Facilitates focusing of lens assembly.
Lens lock release lever (fig. 3-1)-----	Spring-loaded, two-position control:
	<i>Position</i> <i>Action</i>
	Out----- Secures lens assembly in operating position.
	In----- Releases bayonet mount lock to permit removal of lens assembly.
Rewind button (fig. 3-3)-----	Releases film wind mechanism to permit exposed film to be rewound into film cartridge.
Rewind crank (fig. 3-2)-----	Facilitates operation of rewind knob.
Rewind knob (fig. 3-1)-----	Rewinds exposed film into film cartridge.
Self-timer lever (fig. 3-1)-----	Facilitates delay of shutter release from 5 to 15 seconds.
Self-timer release button (fig. 3-1)-----	Starts time delay set by self-timer lever.
Shutter release button (fig. 3-1)-----	Releases cocked shutter mechanism to make an exposure.
Tripod socket (fig. 3-3)-----	Permits camera to be mounted on tripod.

b. *Camera Indicators.* The chart below lists the camera indicators used by the operator and describes their function.

<i>Indicator</i>	<i>Function</i>
Index mark (fig. 3-2) -----	Indicates (on aperture scale) lens aperture to which the aperture ring adjustment control is set.

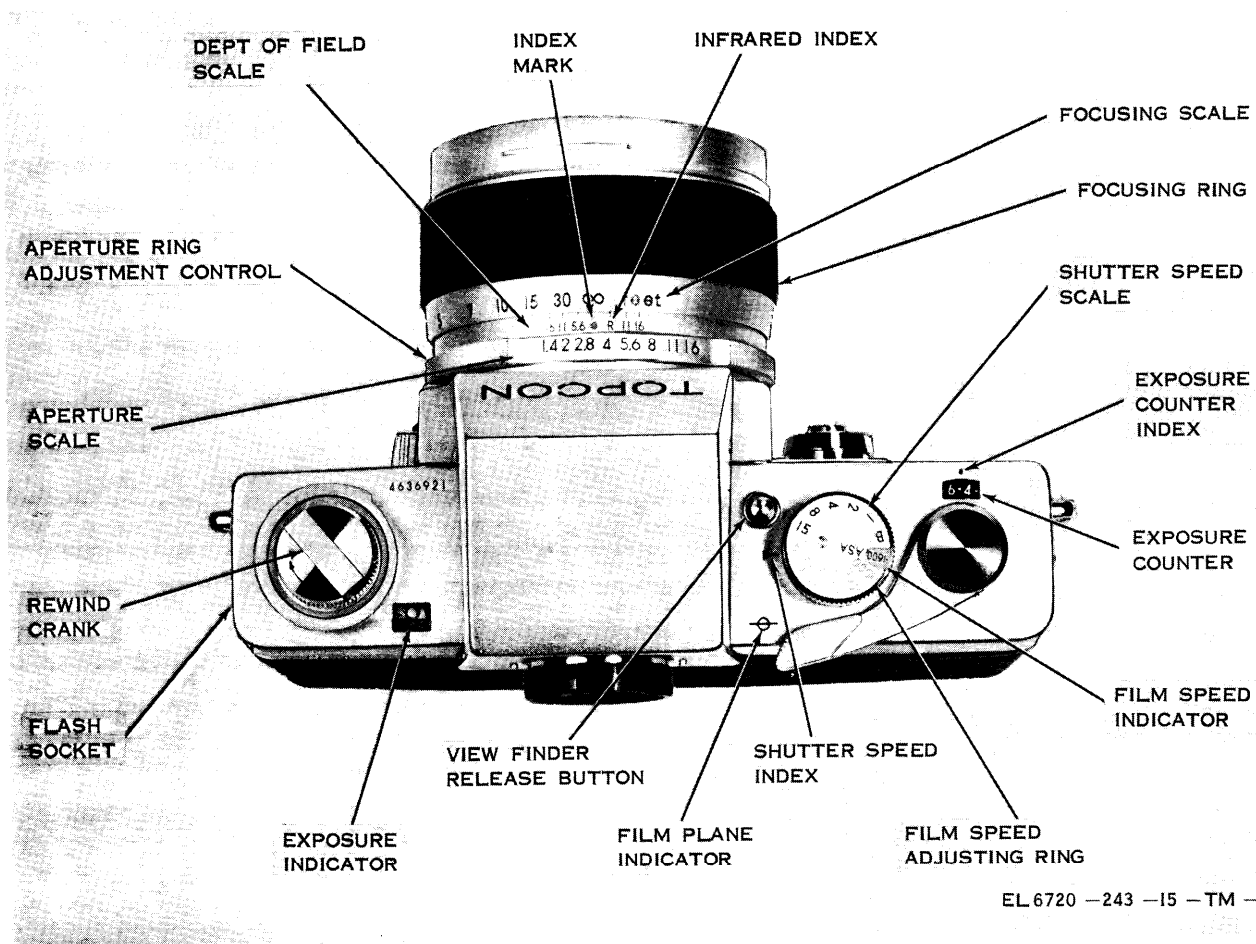

EL 6720 -243 -15 - TM -6

Figure 3-2. Camera controls and indicators, top view.

<i>Indicator</i>	<i>Function</i>
Depth of field scale (fig. 3-2) - - - - -	Indicates zone of acceptable sharp focus for given lens opening (in front of and behind point focused upon).
Exposure counter (fig. 3-2) - - - - -	Indicates number of exposures taken.
Exposure counter index (fig. 3-2) - - - - -	Reference mark for exposure counter.
Exposure indicator (fig. 3-2) - - - - -	Indicates applicable diaphragm (f/stop) opening for given usable light condition.
Film plane indicator (fig. 3-2) - - - - -	Indicates location of film and is used for accurate distant measurements.
Film speed indicator (fig. 3-2) - - - - -	Indicates ASA film speed of film loaded in camera.
Focusing scale (fig. 3-2) - - - - -	When camera is focused, indicates camera to subject distance (in feet and meters).
Index mark (fig. 3-2) - - - - -	Reference mark for aperture and focusing scale settings.
Infrared index (fig. 3-2) - - - - -	Reference mark for focusing correction between white light and infrared rays.
Red dot (fig. 3-8) - - - - -	Indicates starting position for inserting lenses in bayonet mount on camera.
Shutter speed index (fig. 3-2) - - - - -	Reference mark for shutter speed scale.
Shutter speed scale (fig. 3-2) - - - - -	Indicates length of time (in seconds) shutter will remain open during exposure; also indicates when shutter is set up for bulb (B) exposure function.

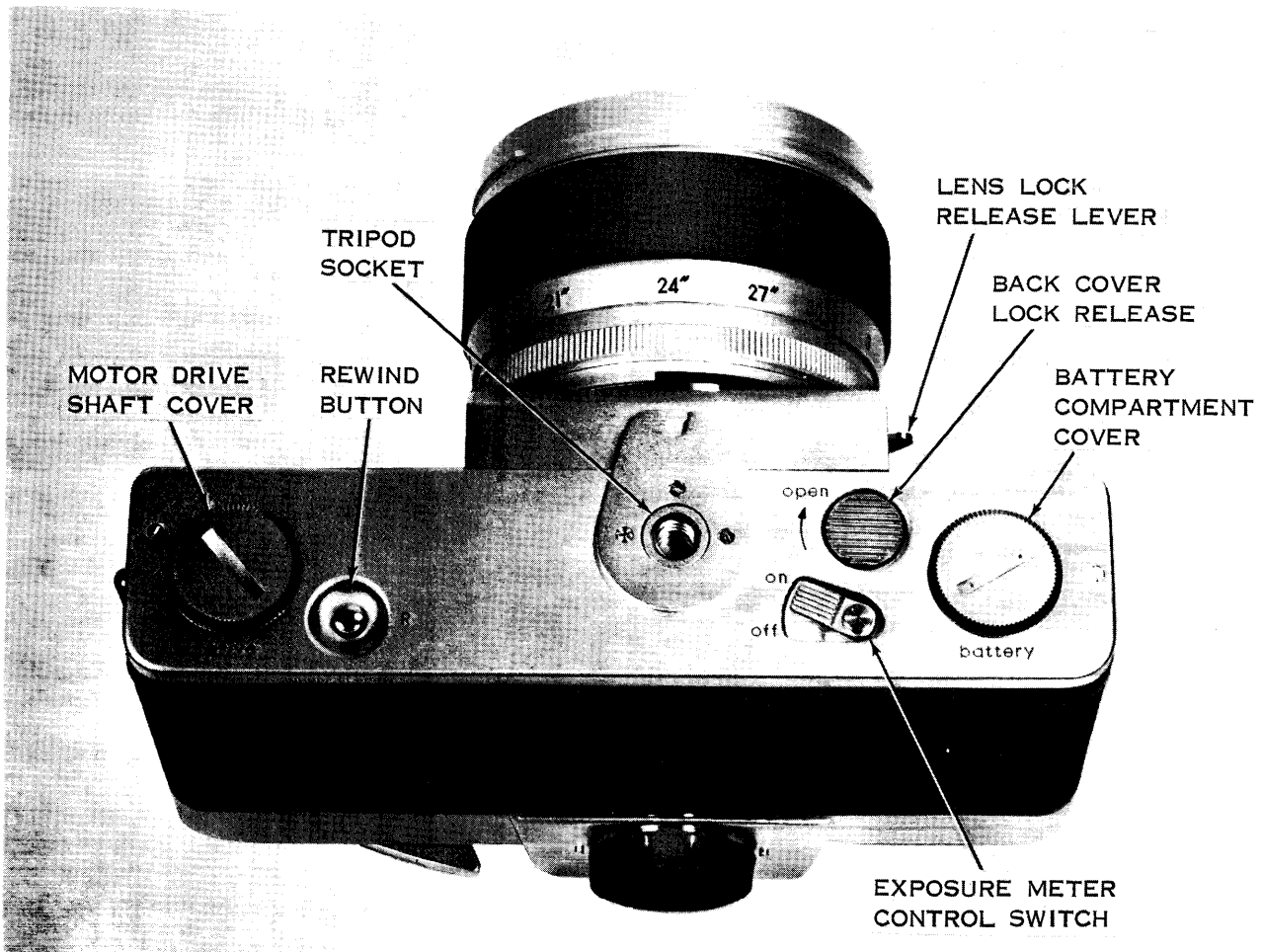

EL6720-243-15-TM-6

Figure 3-3. Camera control and indicators, bottom view.

3-2. Flashgun Controls and Indicators

(fig. 3-4, 3-5)

The charts in *a* and *b* below list the flashgun controls and indicators used by the operator.

a. Controls.

<i>Indicator</i>	<i>Function</i>
Bulb ejector - - - - -	Ejects flashlamps from flashgun.
Calculator setting lever - - - - -	Provides for setting of exposure calculator dial.
Cover release (fig. 5-2)- - - - -	Releases housing assembly cover.
Locking knob - - - - -	Locks flashgun to accessory shoe on camera.
TEST button - - - - -	Tests flashbulbs, battery, and capacitor,

b. Indicators.

<i>Indicator</i>	<i>Function</i>
Distance scale (FEET or METER)- - - - -	Indicates recommended lamp-to-subject distance for given f/stop and guide number.
F/stop scale - - - - -	Indicates recommended f/stop for given lamp-to-subject distance and guide number.
GUIDE NUMBER index (FEET or METER)- - - - -	Reference mark for GUIDE NUMBER (FEET or METER) scale.
GUIDE NUMBER scale (FEET or METER)- - - - -	Indicates flashbulb guide number used.

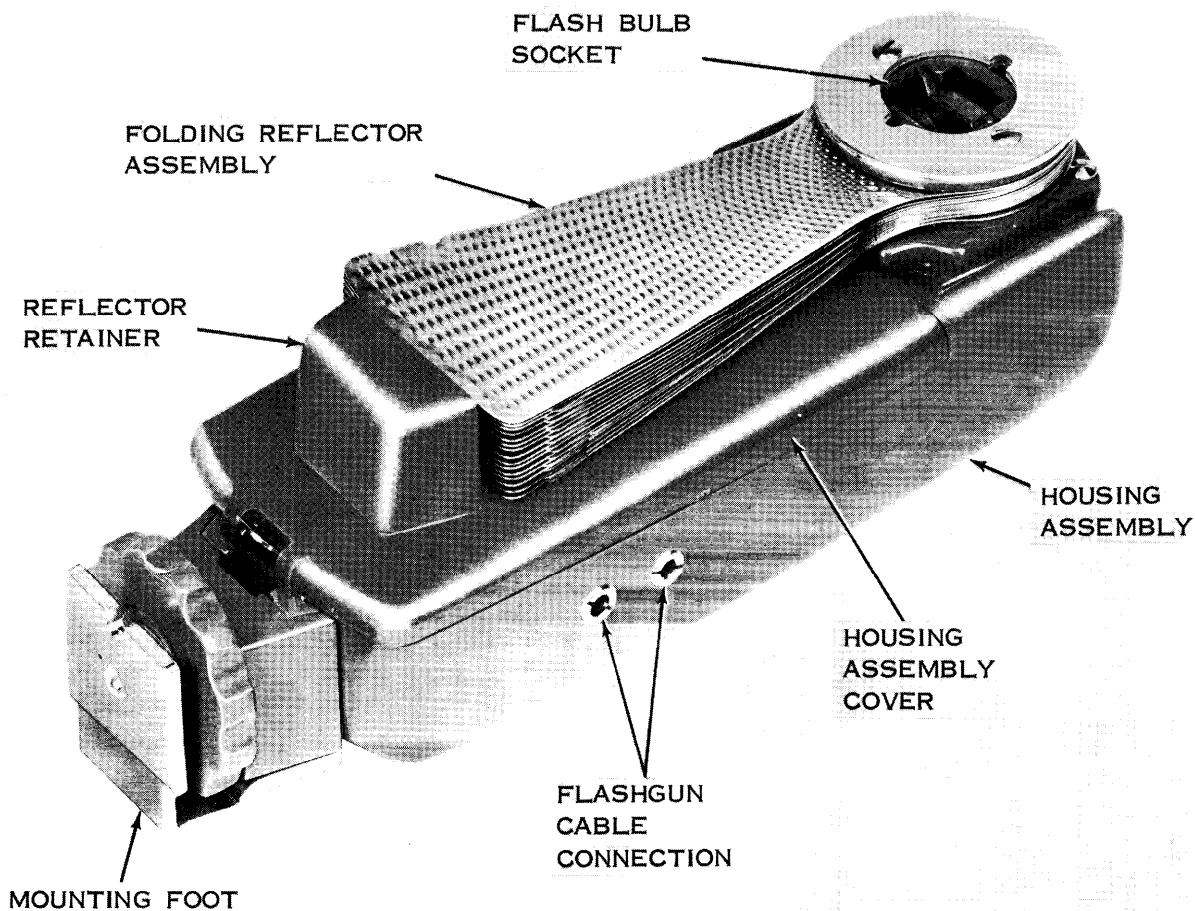

EL 6720 -243 -15 -TM - 8

Figure 3-4. Flashgun with folding reflector closed.

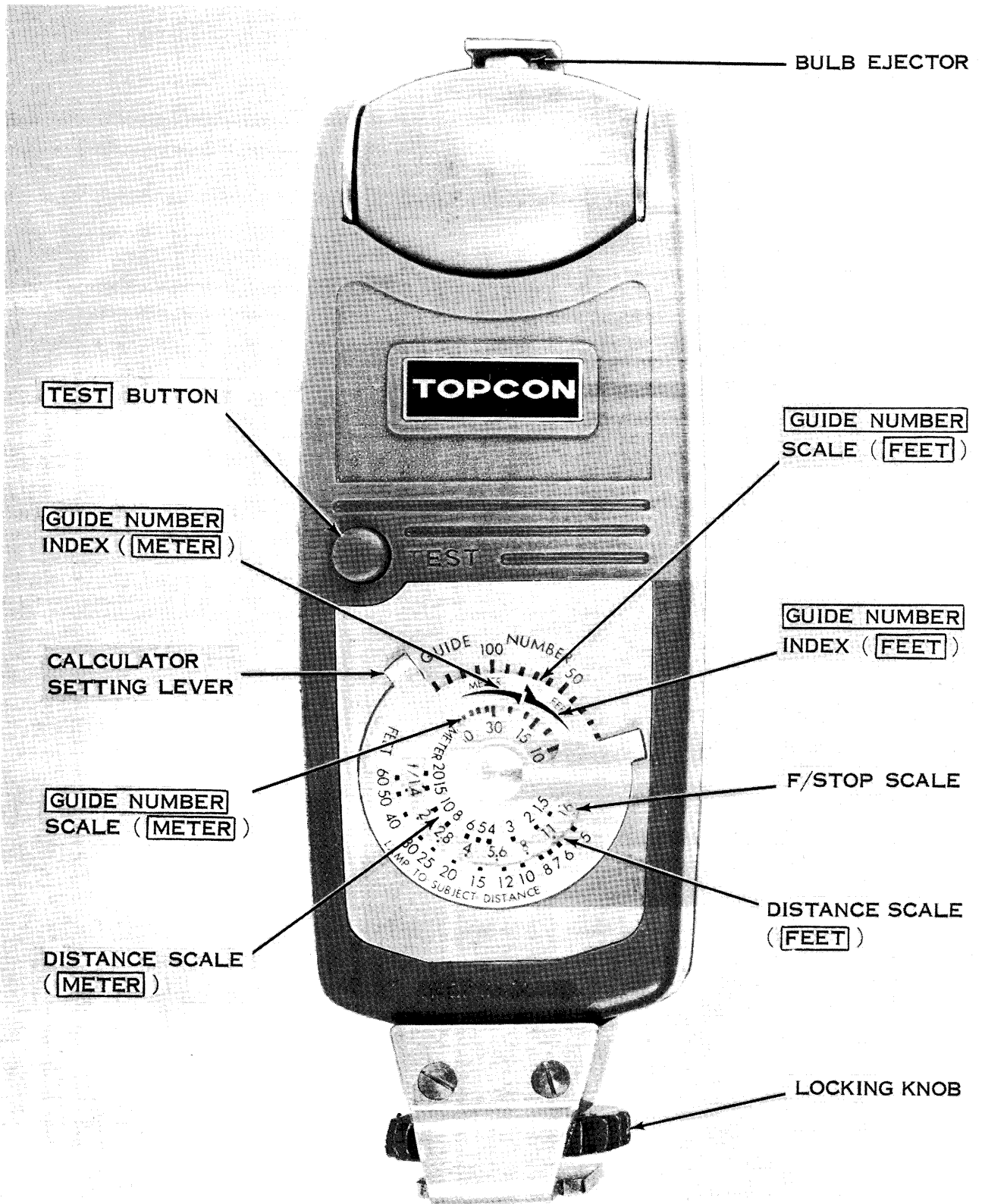

EL6720-243-15-TM-9

Figure 3-5. Flashgun controls and indicators, rear view.

Section II. PRELIMINARY PROCEDURES

3-3. Loading Film in Camera

Always load the camera in subdued light, never in direct sunlight or strong, artificial light. Support the camera firmly when loading to prevent damage from tumbling or dropping.

CAUTION

Do not press the back cover at this time or it will not spring open.

- a. Press and turn the back cover lock release (fig. 3-3) .
- b. Swing the back cover all the way open.
- c. Pull the rewind knob (fig. 3-1) up and out as far as it will go; make sure that the interior of the camera is clean and free of film chips and foreign matter.
- d. Remove a fresh film cartridge from its container and load it into the empty film chamber,

with the leading end of the film leader toward the take up spool. Push in and seat the rewind knob; slightly turn it until it is all the way in.

e. Pull out approximately 6 inches of the film leader and insert the free end into the film clamp on the take up spool (fig. 3-6).

f. Advance the film winding lever (fig. 3-1); make sure that the perforations on the film leader are engaged with the sprocket teeth on the film sprocket (fig. 3-7).

g. Check the film pressure plate to be sure that it is clean and free to move; close the back cover and make sure that it locks. Gently turn the rewind knob (fig. 3-1) in the direction of its arrow; stop turning when it becomes taut.

CAUTION

Observe the rewind knob while advancing the film winding lever; if it does not

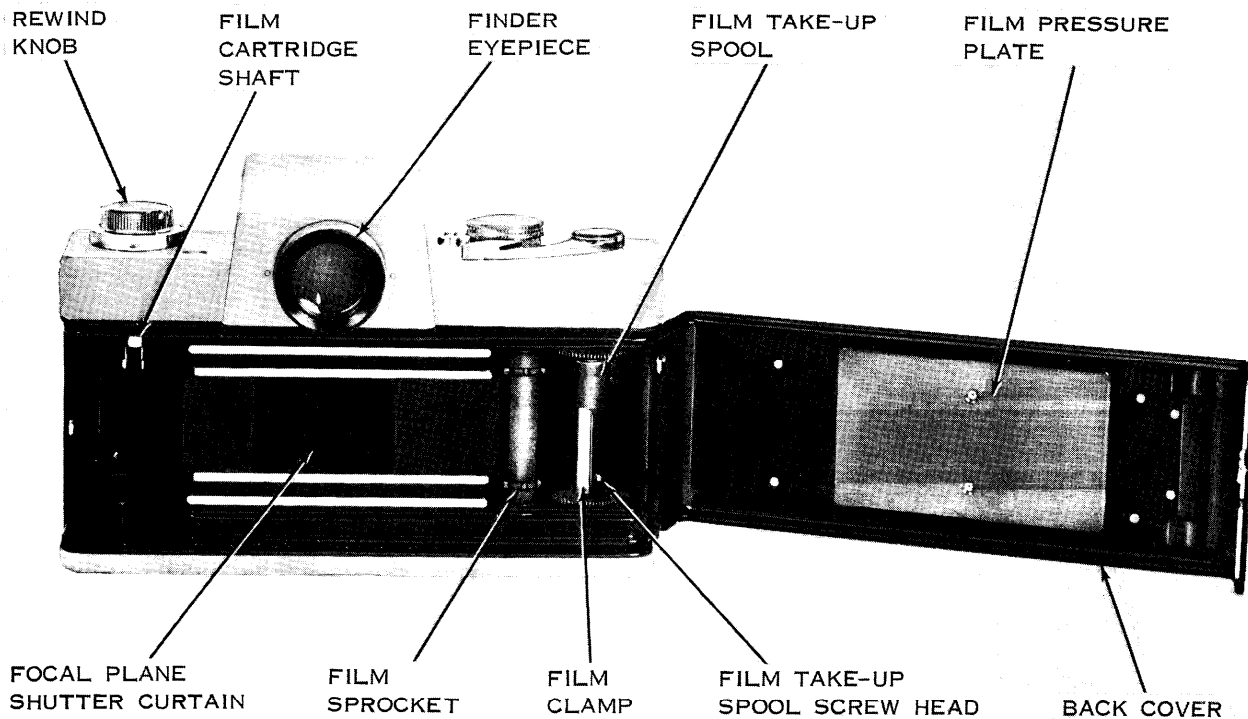

EL6720 -243 -15 -TM -10

Figure 3-6. Camera, back cover open.

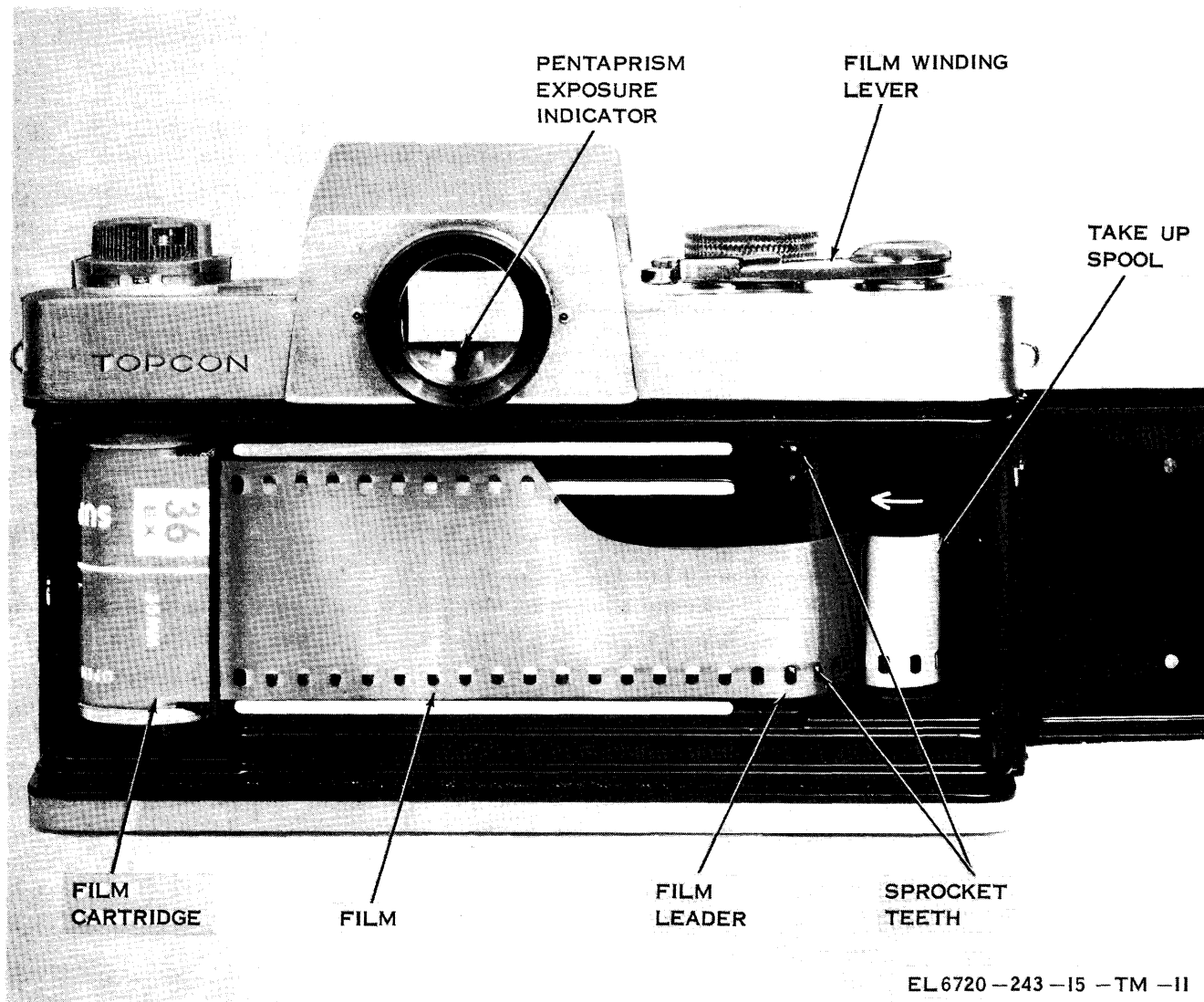

Figure 3-7. Camera, back cover open with film partially threaded.

ASA & BSA	German DIN	European Scheiner	Gost	Weston
25	15/10	26	22	20
32	16/10	27	32	24
40	17/10	28	32	32
50	18/10	29	45	40
64	19/10	30	65	50
80	20/10	31	65	64
100	21/10	32	90	80
125	22/10	33	130	100
160	23/10	34	130	125
200	24/10	35	180	160
250	25/10	36	250	200
320	26/10	37	250	250
400	27/10	38	350	320
500	28/10	39	500	400
650	29/10	40	500	500
800	30/10	41	700	650
1000	31/10	42	1000	800
1250	32/10	43	1000	1000
1600	33/10	44	1500	1250

turn in the opposite direction of its arrow, the film is not being advanced properly.

h. Advance the film winding lever until it stops.

i. Release the shutter, advance the film an additional frame, and release the shutter.

j. Advance the film to the next frame; check to see that the exposure counter is indicating 0.

k. Pull up and revolve the film speed adjusting ring (fig. 3-2) around until the ASA film speed number of the film in the camera is seen.

NOTE

If ASA number is not known, check the instruction sheet in the film package. If film speeds other than ASA are given, use the chart on page 3-7 for conversion to ASA number of the camera.

3-4. Changing Camera Lenses

If a lens assembly other than the normal lens assembly is to be used, proceed as follows:

a. Press the lens lock release lever (fig. 3-1)

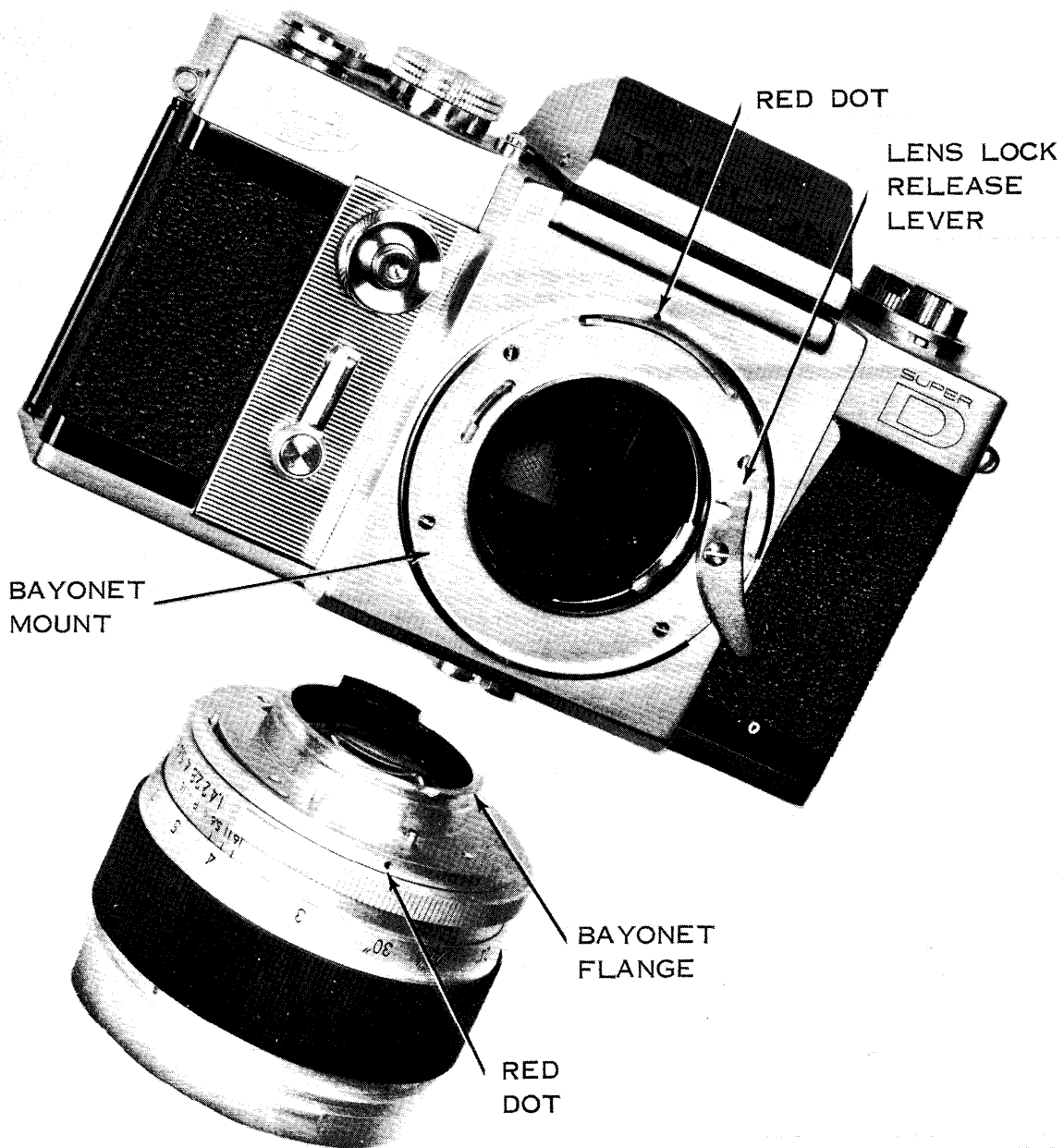

EL6720 -243 -15 -TM -12

Figure 3-8. Camera, normal lens assembly removed.

and rotate the lens assembly counterclockwise until it stops.

b. Gently lift out the lens assembly, and install the applicable front and rear lens caps.

c. Line up the red dot (fig. 3-8) on the replacement lens assembly, and the red dot on the bayonet mount of the camera body.

d. Insert the lens assembly into the camera body so that the bayonet flange engages the bayonet mount; turn the lens assembly clockwise until the lens lock release lever clicks into place.

3-5. Exchanging Viewfinder

If a viewfinder other than the pentaprism is to be used, proceed as follows:

a. For detaching the viewfinder from the camera, depress the viewfinder release button (fig. 3-2) and slowly push out the viewfinder toward the back of the camera.

b. To attach a viewfinder, guide the viewfinder in carefully (the front of the viewfinder should be toward the front of the camera) until it clicks into position (fig. 3-9).

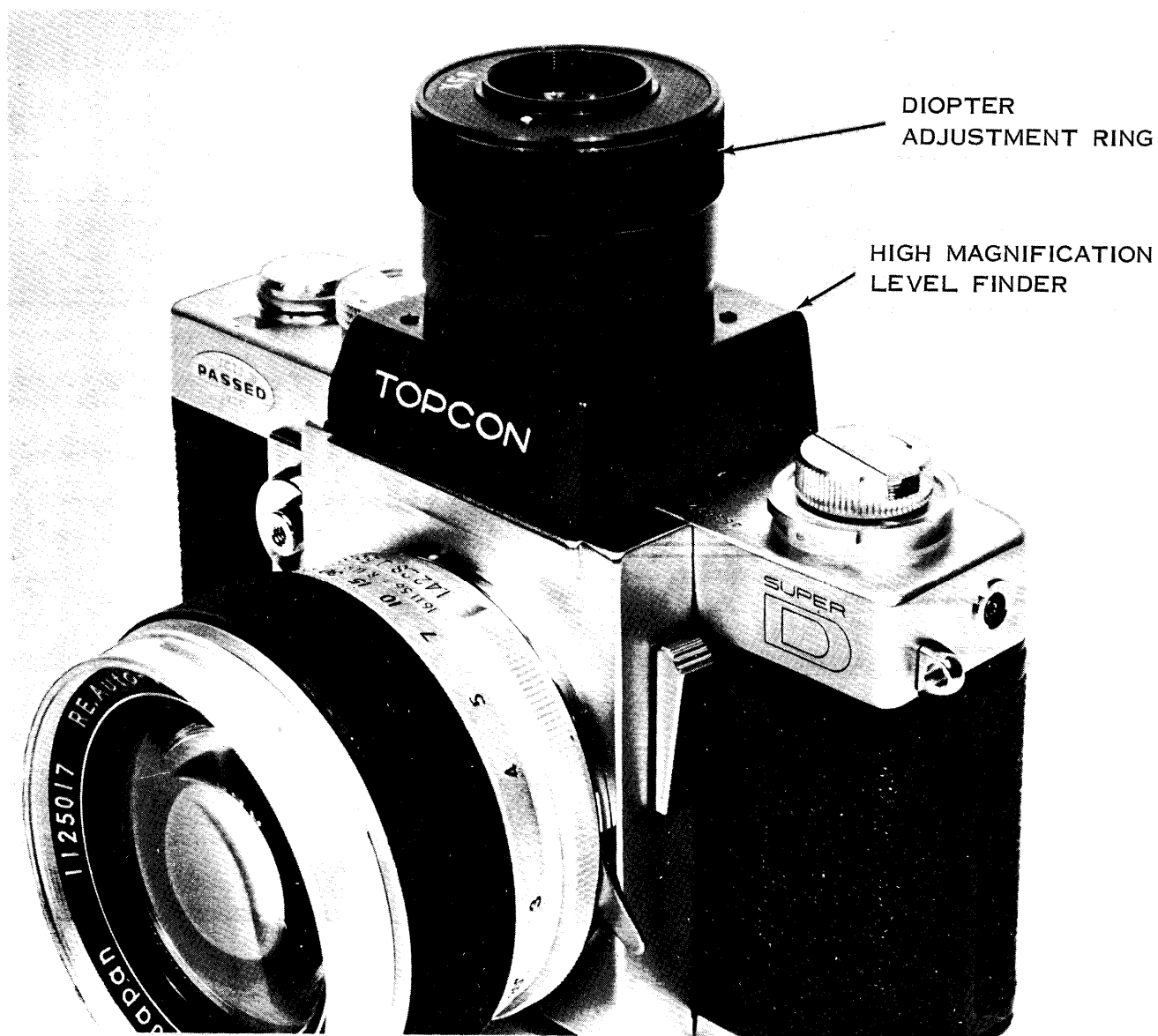

EL6720-243-15-TM-13

Figure 3-9. Camera with high magnification waist level finder.

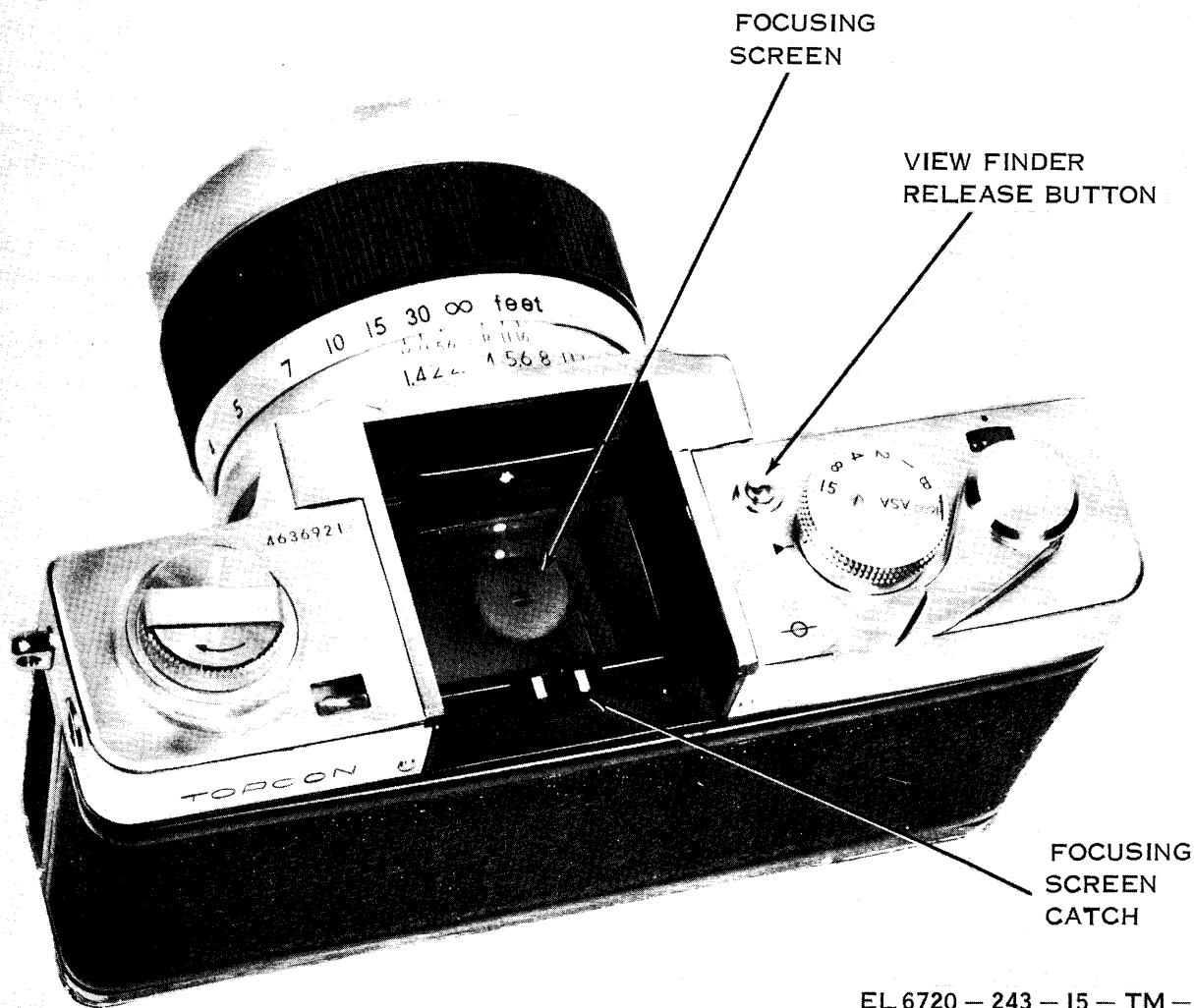

EL 6720 - 243 - 15 - TM - 14

Figure 3-10. Camera with pentaprism view-finder removed.

3-6. Exchanging Focusing Screen

CAUTION

Do not touch the surface of the focusing screen. Do not lift the focusing screen in a dusty place.

If a focusing screen other than the normal split-image screen is to be used, proceed as follows:

- a. Remove the viewfinder (para 3-5a).
- b. Insert a fingernail under the focusing screen catch (fig. 3-10) and lift up and remove the focusing screen.
- c. Place the other focusing screen into the camera and press down on the focusing screen catch to secure the focusing screen in place.

- d. Replace the viewfinder (para 3-5 b).

3-7. Exposure Reading

(fig. 3-11 and 3-12)

a. *Pentaprism Exposure Indicator.* Obtain an exposure reading through the pentaprism exposure indicator as follows:

- (1) Set the exposure meter control switch (fig. 3-3) to ON.
- (2) Point the camera at the subject and fully fill the focusing screen with the subject.
- (3) Adjust either the shutter speed or aperture, or both, until the T-indicator is correctly aligned in the V-indicator mark (fig. 3-12).

b. *Camera Top Deck Exposure Indicator.* O b

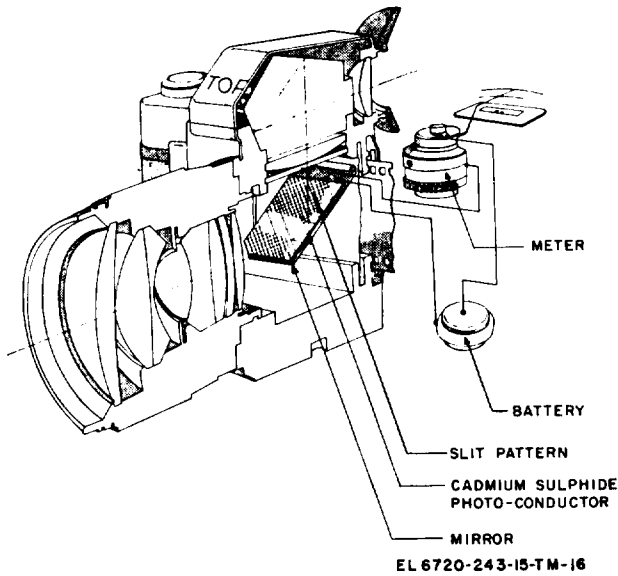

Figure 3-11. Meter system diagram.

tain an exposure reading, using the exposure indicator on the camera top deck, as follows:

- (1) Set the exposure meter control switch (fig. 3-3) to ON.
- (2) Point the camera at the subject and fully fill the focusing screen with the subject.
- (3) Adjust either the shutter speed or aperture, or both, until the crosshairs are in the center of the circle of exposure indicator (fig. 3-12).

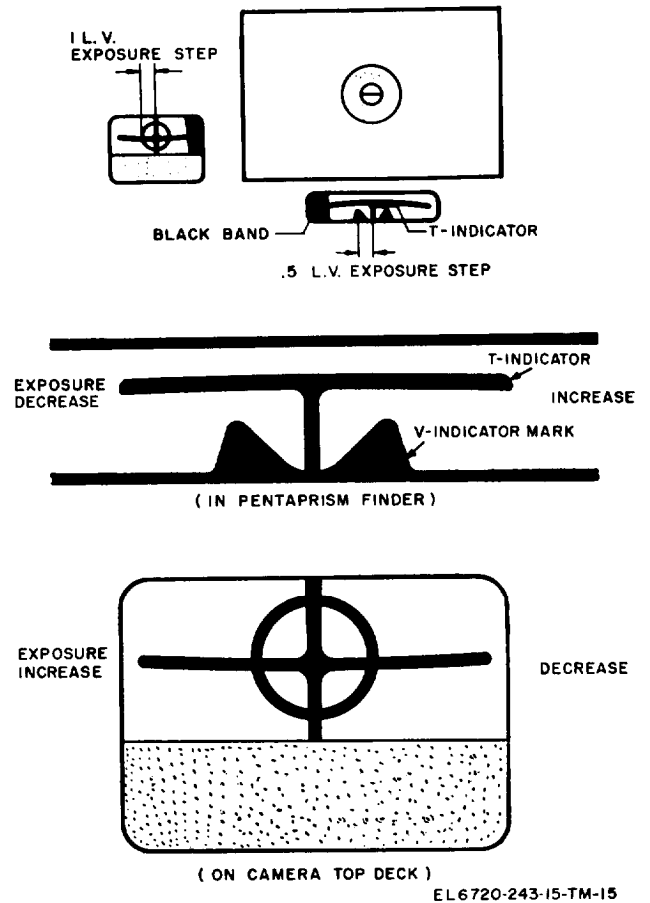

Figure 3-12. Exposure Indications.

Section III. OPERATION UNDER USUAL CONDITIONS

3-8. Available light Photography Operation

- a. Check to see that the camera has been loaded with film (para 3-3), and the film speed adjusting ring (fig. 3-2) has been set to the correct ASA setting.
- b. Set the exposure meter control switch to ON.

- c. Set the shutter speed to the desired setting.
- d. Advance the film winding lever (fig. 3-1) to cock the shutter and advance the film.
- e. View the subject through the viewfinder; turn the focusing ring until the subject is sharply in focus (fig. 3-13).

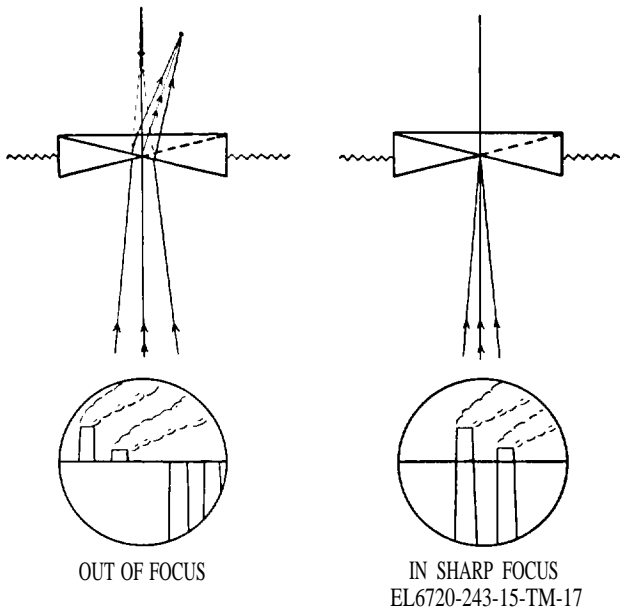

Figure 3-13. Focusing split image range finder.

f. Compose the picture in the viewfinder. If previewing the depth of field is desired, press and hold the depth of field preview lever (fig. 3-1).

g. Check the exposure indicator (para 3-7). If the exposure is correct, press the shutter release button.

3-9. Flash Photography Operation

a. Check to see that the camera has been properly loaded with film (para 3-3).

b. Place the flashgun coupler over the bayonet mount on the rewind knob (fig. 3-14) and turn the knurled ring to attach it firmly.

c. Raise the locking knob by turning it upon its threaded shaft; slide the mounting foot into the flashgun coupler (fig. 3-15).

d. Open the folding reflector assembly and lock it in the desired slot (normal for close subject, or distant for subject beyond 15 feet) (fig. 3-15).

e. Set the shutter speed to the desired speed. Be sure to select a shutter speed that will synchronize class of flashbulb being used (fig. 3-16).

f. Set the flash calculator (fig. 3-5) to the recommended GUIDE NUMBER scale setting for the film and flashbulb combination to be used.

NOTE

Guide numbers for various film, flashbulb, and shutter combination are

usually found in the instruction literature with the flashbulbs to be used.

g. View the subject through the viewfinder; turn the focusing ring until the subject is sharply in focus.

h. Read the camera to subject distance on the focusing scale; use the flash calculator indication and set the aperture ring adjustment control to the indicated f/stop.

i. Advance the film winding lever to cock the shutter and advance the film.

j. Insert the flashgun in the bulb socket.

k. Press the flashgun TEST button (fig. 3-5) to check the condition of the flashbulb, battery, and capacitor.

l. View the subject through the viewfinder; compose the picture. If previewing the depth of field is desired, press and hold the depth of field preview lever (fig. 3-1).

m. Press the shutter release button.

CAUTION

Avoid handling recently fired flashbulbs; injury from burns may result.

n. Press the bulb ejector on the flashgun to release the expended flashbulb.

NOTE

If the flashgun is to be operated off the camera, connect the flashgun cable as shown in figure 3-17.

3-10. Infrared Photography

a. *General.* Infrared film is sensitive only to the blue-violet infrared wavelengths; however, ordinary panchromatic film is sensitive to all the colors of the spectrum. Because infrared rays are not visible color and are longer in wavelength than visible red rays, they cannot be used for focusing. To insure proper focusing for infrared film, follow the steps given in *b* below. For a true infrared rendition of the subject, a Wratten No. 25 filter must be used to cut out the blue (in the blue-violet wavelength), as infrared film is also sensitive to this wavelength.

b. *Infrared Photography Procedures.*

(1) Screw the Wratten No. 25 filter into the lens.

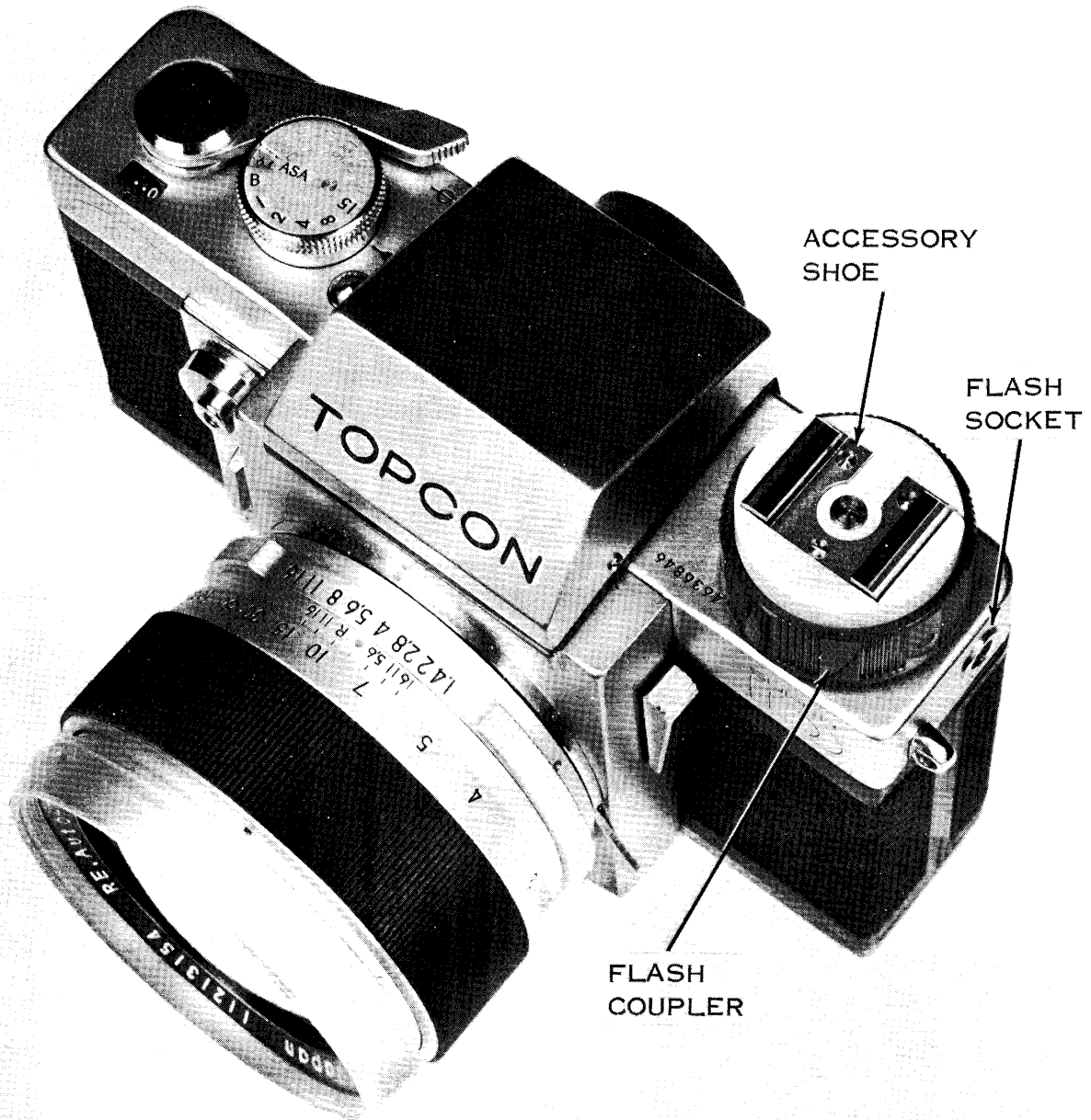

EL6720-243-15-TM-18

Figure 8-14. Flashgun coupler mounted on camera,

(2) Check to see that the camera has been loaded with film (para 3-3), and the film speed adjusting ring (fig. 3-2) has been set to the correct ASA setting.

(3) Set the exposure meter control switch to ON.

(4) Set the shutter speed to the desired setting.

(5) Advance the film winding lever (fig. 3-1) to cock the shutter and advance the film.

(6) View the subject through the viewfinder; turn the focusing ring until the subject is sharply in focus (fig. 3-13).

(7) Set the distance setting obtained in (6) above to the infrared index (fig. 3-2).

(8) Compose the picture in the viewfinder. If

FOLDING REFLECTOR

DISTANT SLOT

NORMAL SLOT

LOCKING KNOB

FLASHGUN COUPLER

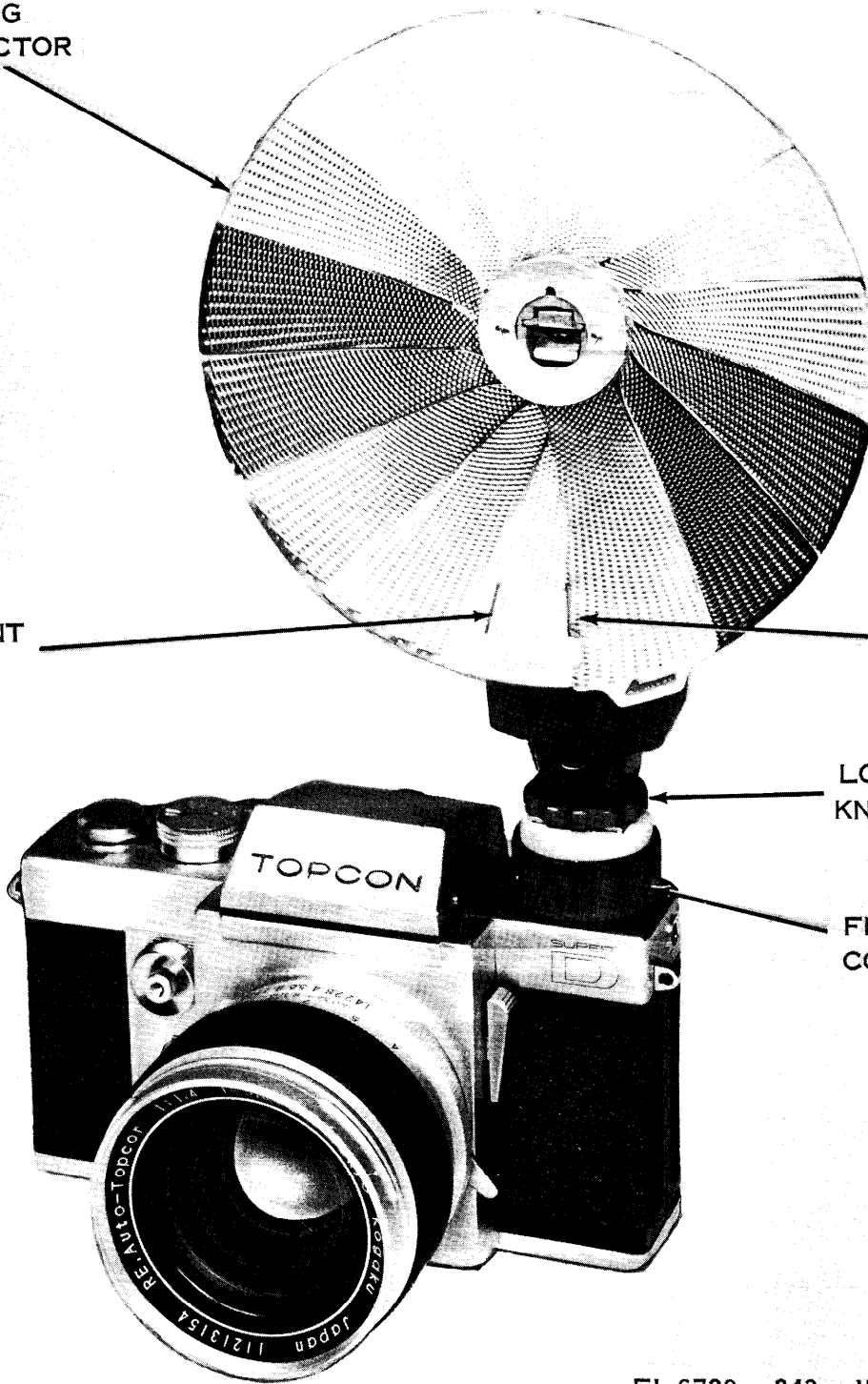

EL 6720 - 243 - 15 - TM - 19

Figure 3-15. Flashgun mounted on camera.

FLASH BULB			SHUTTER SPEED											
CLASS	MAKE		1000	500	250	125	60	30	15	8	4	2	1	B
FP	G.E.	PH/6	[Hatched]				[Blank]		[Hatched]					
	SYLVANIA	TYPE FP26												
	TOSHIBA	NO. 6 NO. 62												
F	G.E.	PH/SM	[Blank]				[Hatched]							
	SYLVANIA	TYPE SF												
	TOSHIBA	F1 F3 F5												
M	G.E.	PH/5 M5	[Blank]				[Hatched]							
		PH M2AG-1												
	SYLVANIA	PRESS 25M-5												
		TYPE M2 AG-1												
	TOSHIBA	Z-PRESS NO.3												
		2M US-1												
X	ELECTRONIC FLASH		[Blank]				[Hatched]							

EL6720-243-15-TM-20

Figure 3-16. Flashbulb synchronization chart.

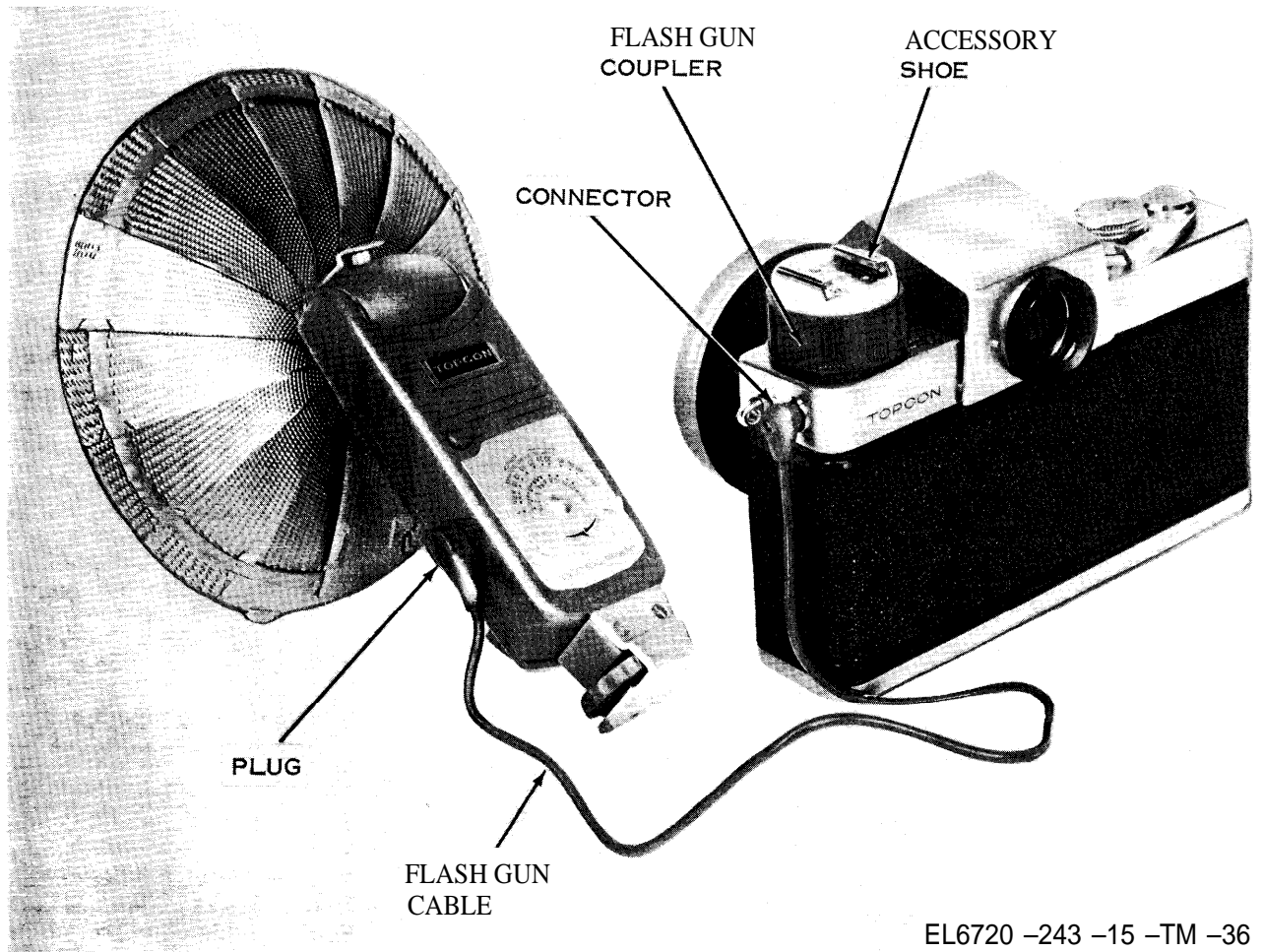

EL6720 -243 -15 -TM -36

Figure 3-17. Flashgun connector off camera.

previewing the depth of field is desired, press and hold the depth of field preview lever (fig. 3-1).

(9) Check the exposure indicator (para 3-7). If the exposure is correct, press the shutter release button.

3-11. Self-Timer Operation

(fig. 3-18)

a. *General.* For acting as your own assistant and holding lighting equipment, or for minimizing camera vibration on the tripod, the built-in self-timer is a useful mechanism. It permits delayed shutter releases between 5 and 15 seconds.

b. *Setting Self-Timer.*

(1) Change the self-timer by pushing down the self-timer lever 180° (fig. 3-18). At the 180°

position, the delay will be a maximum of 15 seconds; and at intermediate positions, the delay will be anywhere from 5 to 15 seconds. The self-timer may be changed before or after the shutter speed is set, and before or after film winding action.

(2) Depress the self-timer release button. The self-timer may be bypassed at any time by depressing the shutter release button in the usual way.

3-12. Stopping Procedures

a. Check the exposure counter (fig. 3-2) to see if the last exposure has been taken (20 or 36, depending on which length of film was loaded in the camera).

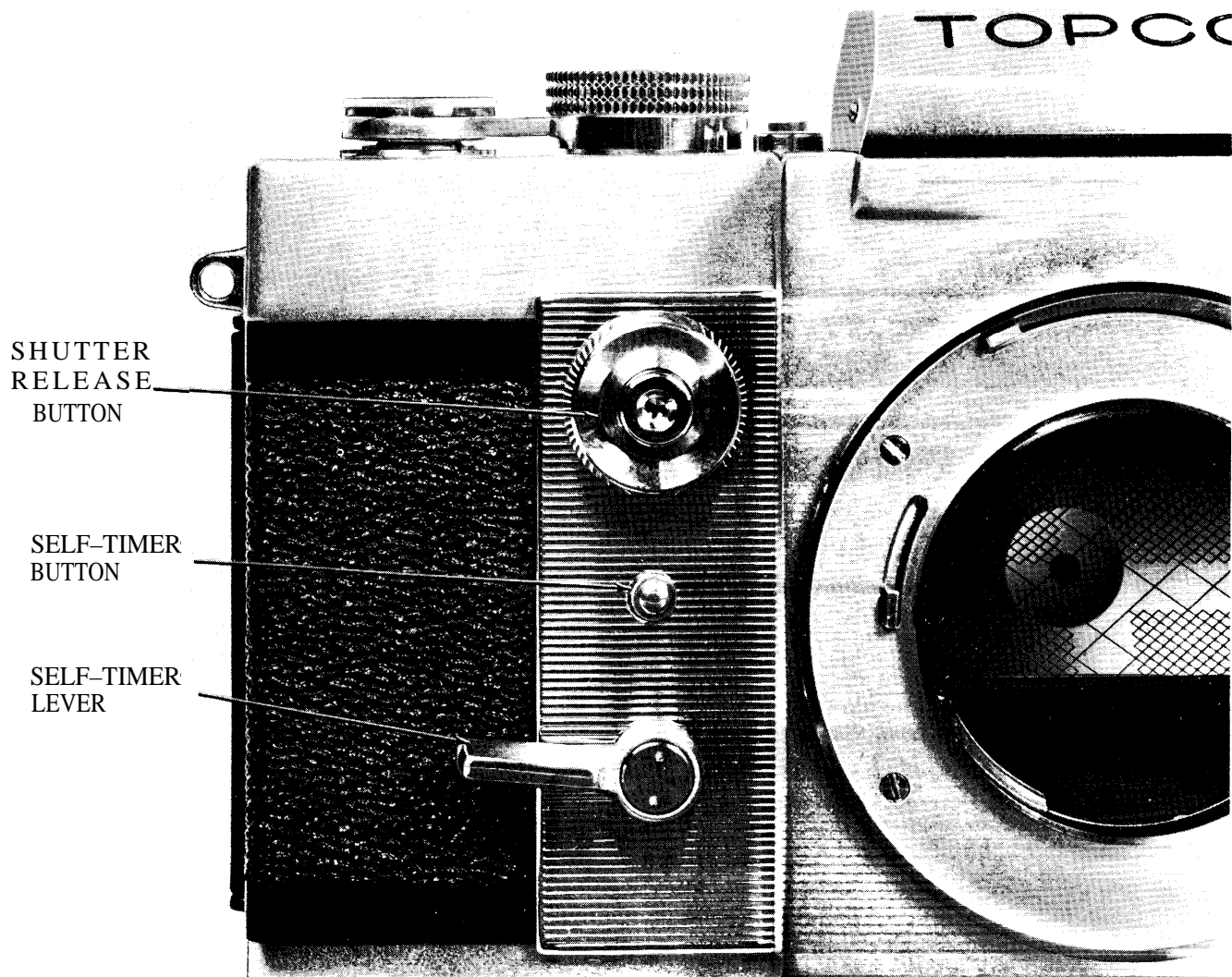

EL6720 -243 -15 -TM -37

Figure 3-18. Camera with self-timer lever cocked.

b. Remove the flashgun, flashgun coupler, and filter and lens hood (if any were used) from the camera; clean the components (para 47) and return them to their respective compartments in the carrying case (fig. 2-2).

c. Press in the rewind button (fig. 3-3).

d. Lift the rewind crank (fig. 3-2) on the rewind knob.

e. Wind the rewind crank clockwise (indicated by the arrow) until the film is rewound into the cartridge.

NOTE

Do not open the camera back until the film is completely wound into the film

cartridge, or the film will be ruined by exposure to the light.

f. Press in and turn the back cover lock release (fig. 3-3) to unlock the back cover

g. Open the back cover; lift up the rewind knob and remove the film cartridge which contains the exposed film,

h. Press down the rewind crank and rewind knob; close the back cover until it snaps shut.

i. Clean the camera (para 47) and replace the lens cap,

j. Set the exposure meter control switch to OFF and return the camera to the carrying case.

Section IV. OPERATION UNDER UNUSUAL CONDITIONS

3-13. Operation at Low Temperatures

The camera set can be operated at low temperatures if the procedures given in *a* and *b* below are followed:

a. Equipment to be operated at low temperatures should be stored at approximately the same temperature as that in which it will be used. Avoid rapid changes in the equipment temperature. If the equipment is stored in a colder location than where it will be used, follow the procedures given in (1), (2), and (3) below.

(1) Transfer the equipment from the low-temperature storage location to the warmer location at least 6 hours in advance of its anticipated use.

(2) Before operating the equipment, wipe off any moisture on the outer plastic and metal surfaces of the equipment with a soft, lint-free cloth.

(3) Inspect the optical surfaces of the finder assembly and the lens assemblies for moisture. If moisture is present on the exposed optical surfaces, clean the exposed optical surfaces with a lens tissue dampened with lens cleaner. Dry the exposed optical surface with a clean lens tissue.

NOTE

If moisture has condensed on the inner surfaces of the optical components, allow the equipment to stand long enough for the moisture to evaporate. Allow the equipment to stand in a warm area to evaporate the moisture more rapidly. Do not allow the temperature to exceed +125° F.

b. When the camera set is to be operated at low temperatures, follow procedures given in (1), (2) and (3) below.

(1) Keep the equipment in low-temperature storage when it is not in use. Use precautions to prevent moisture from forming on the camera and the flashgun parts, particularly on the optical assemblies.

(2) Avoid breathing directly on the equipment while it is at a low temperature.

(3) Provide additional precautions and protection to the equipment while it is in storage to prevent its exposure to high humidity accompanied by freezing temperature.

3-14. Operation in Desert Areas or in Dust-Laden Atmosphere

When the camera set is used in desert areas or other dust-laden atmospheres, follow procedures given below.

a. Expose the equipment to dust-laden air for only minimum lengths of time.

b. Be sure that the flashgun is free of excessive dust before attaching it to the camera

c. Return the equipment to the carrying case as soon as possible after each use.

d. When the equipment is not in actual use, keep all components of the camera set in the carrying case.

e. Check the equipment frequently to see if cleaning is required.

3-15. Operation in Tropical Regions

When the camera set is used in tropical regions, follow procedures given below.

a. Inspect the equipment daily for fungus, mites, and metal corrosion. Clean the equipment (para 4-7b), and remove all fouling matter immediately.

b. Keep all components of the camera set in the carrying case when the equipment is not in use.

c. When the camera set is used, take additional precautions to prevent insects from entering the equipment. Do not leave the camera set exposed to insect-infested locations.

CHAPTER 4
OPERATOR'S MAINTENANCE INSTRUCTIONS

4-1. Scope of Operator's Maintenance

The maintenance duties assigned to the operator of the camera set are listed below, together with references to the paragraphs covering the specific maintenance function. The duties assigned do not require materials other than those specified in paragraph 4-2.

- a. Operator's daily preventive maintenance checks and services chart (para 4-5).
- b. Operator's weekly preventive maintenance checks and services chart (para 4-6).
- c. Visual inspection and cleaning (para 4-7).
- d. Troubleshooting (para 4-8 and 4-9).

4-2. Materials Required

The materials required to perform the operator's maintenance are as follows:

- a. Lint-free cloth.
- b. Camel's-hair brush.
- c. Trichloroethane.

4-3. Operator's Preventive Maintenance

Operator's preventive maintenance is the systematic care, servicing, and inspection of equipment to prevent the occurrence of trouble, reduce downtime, and assure that the equipment is serviceable.

a. *Systematic Care.* The procedures given in paragraphs 4-5, 4-6, and 4-7 cover routine systematic care and cleaning essential to the proper upkeep and operation of the equipment.

b. *Preventive Maintenance Checks and Services.* The operator's preventive maintenance checks and services charts (para 4-5 and 4-6) describe functions to be performed at specific intervals; however, if the equipment is used as part of a set or

system, the procedures given in the set or system manual should be followed. These checks and services are to maintain Army equipment in a serviceable condition; that is, in good operating condition. To assist operators in maintaining serviceability, the charts indicate what to check and how to check; the *References* column lists paragraphs that contain additional data on prescribed procedures. Records and reports of these checks must be made in accordance with the requirements set forth in TM 38-750.

4-4. Operator's Preventive Maintenance Checks and Services Periods

Operator's preventive maintenance checks and services of the camera set are required daily and weekly.

a. Paragraph 4-5 specifies the checks and services that must be accomplished daily (when the equipment is in use), and under the following conditions:

- (1) When the equipment is initially installed.
- (2) When the equipment is reinstalled after removal for any reason.
- (3) At least once each week if the equipment is maintained in standby condition.

b. Paragraph 4-6 specifies checks and services that must be performed weekly. A week is defined as approximately 7 calendar days of 8-hour-per-day operation. If the equipment is operated more than 8 hours a day, the maintenance should also be performed at weekly intervals to compensate for any unusual operating conditions. Equipment maintained in a *standby* (ready for immediate operation) condition must have weekly maintenance. Equipment in *limited storage* (requires service before operation) does not require weekly maintenance.

4-5. Operator's Daily Preventive Maintenance Checks and Services Chart

<i>Sequence No.</i>	<i>Item to be inspected</i>	<i>Procedure</i>	<i>References</i>
1	Completeness-----	Check to see that equipment is complete-----	Para 1-6.

Sequence No.	Item to be inspected	Procedure	References
2	Cleanliness -----	Check to see that equipment is clean -----	Para 4-7.
3	Operation -----	During operation, be alert for any unusual operating conditions. Listen for unusual sounds when winding, rewinding, and operating shutter release, Feel for binding or erratic operation of controls, and film winding lever.	Para 3-8 through 3-11.

4-6. Operator's Weekly Preventive Maintenance Checks and Services Chart

Sequence No.	Item to be inspected	Procedure	References
1	Lenses and filters -----	Check all lenses and filters for dust, dirt, haze, fingermarks, and moisture. Check bayonet mounts. <i>Note.</i> Do not attempt to disassemble lenses for removal of foreign matter, or touch mirror in camera.	Para 4-7.
2	Camera body -----	Remove dust, dirt, and moisture from camera exterior and film chamber. Check door hinge and lock. Clean metal surfaces of camera body.	Para 4-7.
3	Lens hoods -----	Inspect lens hoods for cracks or damaged threads-----	Para 4-7a.
4	Camera controls -----	Check all controls for looseness, binding, scraping, and positive operation.	Para 3-1.
5	Flashgun-----	Check condition of reflector, battery, capacitor, test lamp, and connecting cord. Check battery contacts and flashgun surfaces.	Para 4-7a.
6	Carrying case and minor components.	Inspect all minor components for completeness and condition. Clean carrying case inside and outside; remove all dirt, dust, moisture, and foreign matter. Check condition of strap and case latch.	Para 4-7.

4-7. Visual Inspection and Cleaning

Visual inspection and cleaning will often save time and prevent further damage to the camera set. When the equipment fails to perform properly, check for the possible defects given in a below. If necessary, have defective part repaired (or replaced) as soon as possible by appropriate maintenance personnel. Clean the camera set as directed in *b* below as often as necessary.

a. *Visual Inspection.* Make a general visual inspection of the camera set; check for obvious defects as follows:

- (1) Examine the camera set for cracks, dents, moisture damage, or dirt.

CAUTION

Do not touch the mirror.

- (2) Check optical surfaces for chipped, cracked, scratched, or dirty surfaces.
- (3) Open the back cover; check to see that the exposure counter returns to 0.
- (4) Check the film takeup spool and the film sprocket for damage, and the film pressure plate for scratches or damage.
- (5) Check the flash socket for damage.
- (6) Check all camera controls for proper operation and damage.

- (7) Check the flashgun for a damaged reflector, a broken case, a frayed connection cable, or a damaged flashbulb socket.

- (8) Check the carrying case hinges and the latch and strap for damage or dirty condition.

b. *Cleaning.*

- (1) Remove loose dirt from metal and plastic surfaces with a dry, lint-free cloth.
- (2) Remove loose dirt from hard-to-reach surfaces with a clean brush.
- (3) Remove dust and dirt from the carrying case with the lens brush.

CAUTION

Do not touch the mirror.

- (4) Clean the optical surfaces with the lens brush, a lens tissue, the lens cleaner, and the air syringe.
- (5) Remove any dust from the film chamber, the pressure plate, and the rear of the camera with the air syringe or the lens brush.
- (6) Remove dust and dirt from the flashgun, the reflector, and the lamp socket with the lens brush and a lint-free cloth.
- (7) Remove dirt and dust from the carrying case exterior with a clean, lint-free cloth dampened with water; wipe dry.

WARNING

The fumes of trichloroethane are toxic. Provide through ventilation whenever used. DO NOT use near an open flame. Trichloroethane is not flammable, but exposure of the fumes to an open flame converts the fumes to highly toxic, dangerous gases.

(8) Clean the soil from metal parts with trichloroethane and wipe them dry with a lint-free cloth.

4-8. Operator's Troubleshooting Information

The troubleshooting chart (para 4-9) helps the operator to find and correct certain troubles. The

troubles and corrective measures listed are those which the operator can accomplish. If the corrective measures suggested do not restore normal equipment performance, do not attempt to disassemble the defective camera set component. Note on the repair tag what corrective measures were taken, how the equipment performed at the time of failure, and refer the equipment to the next higher category of maintenance for repair.

4-9. Operator's Troubleshooting Chart

The chart below lists the trouble symptom, the probable trouble, and the corrective measures that are common to normal light photography (a below) and flash photography (b below).

a. Normal Light Photography.

<i>Item No.</i>	<i>Trouble symptom</i>	<i>Probable trouble</i>	<i>Checks and corrective measures</i>
1	No exposure -----	<ul style="list-style-type: none"> a. Film improperly threaded in camera. b. Shutter inoperative ----- c. Defective film ----- d. Film advance defective ----- 	<ul style="list-style-type: none"> a. Load film properly (para 3-3). b. Refer to higher category of maintenance. c. Use film of good quality. d. Refer to higher category of maintenance.
2	Improper exposure -----	<ul style="list-style-type: none"> a. Weak battery ----- b. Wrong shutter speed or f/stop setting. 	<ul style="list-style-type: none"> a. Refer to higher category of maintenance. b. Use exposure indicator or exposure charts.
3	Film will not advance -----	<ul style="list-style-type: none"> a. Film improperly threaded in camera. b. Film past last exposure ----- c. Winding mechanism defective ----- 	<ul style="list-style-type: none"> a. Load film properly (para 3-3). b. Rewind film into film cartridge. c. Refer to higher category of maintenance.
4	Film cannot be rewound -----	<ul style="list-style-type: none"> a. Rewind button not depressed ----- b. Film pulled off supply spool ----- 	<ul style="list-style-type: none"> a. Press rewind button. b. Open camera in darkroom, and replace film in film cartridge.
5	Meter inoperative -----	<ul style="list-style-type: none"> a. Battery exhausted ----- b. Meter defective ----- 	<ul style="list-style-type: none"> a. Refer to higher category of maintenance. b. Refer to higher category of maintenance.
6	Scratches on negative -----	<ul style="list-style-type: none"> a. Film pressure plate defective ----- b. Dust or dirt in film path ----- 	<ul style="list-style-type: none"> a. Check <i>film</i> pressure plate (para 3-39) b. Clean inside rear of camera (para 4-7b).
7	Light leaks on film -----	<ul style="list-style-type: none"> a. Back cover not closed completely -- b. Back cover opened before film was rewound into film cartridge. c. Extraneous light entering camera-- 	<ul style="list-style-type: none"> a. Close back cover completely when loading. b. Rewind film before opening back cover. c. Refer to higher category of maintenance.

b. Flash Photography.

<i>Item No.</i>	<i>Trouble symptom</i>	<i>Probable trouble</i>	<i>Checks and corrective measures</i>
1	Flashbulb does not flash when body release is pressed.	<ul style="list-style-type: none"> a. Flashgun cable or flash socket defective. b. Defective flashbulb ----- c. Battery or capacitor defective ----- 	<ul style="list-style-type: none"> a. Refer to higher category of maintenance. b. TEST button on flashgun should be pressed to check flashbulbs. c. Refer to higher category of maintenance.

<i>Item No.</i>	<i>Trouble symptom</i>	<i>Probab/e trouble</i>	<i>Checks and correcting measures</i>
		d. Shutter contacts or flashgun coupler defective.	d. Refer to higher category of maintenance.
2	Improperly exposed negatives.	a. Shutter speed improperly set	a. Set shutter speed to proper setting (para 3-7).
		b. Folding reflector improperly adjusted.	b. Adjust folding reflector properly (para 3-9).
3	Flashbulb flashes when <i>inserted</i> into flash socket.	Short in shutter, flashgun cable, flashgun, or flash socket.	Refer to higher category of maintenance.
4	Test lamp does not light when TEST button is pressed.	a. Flashbulb defective - - - - -	a. Replace flashbulb.
		b. Capacitor or battery defective- - - -	b. Refer to higher category of maintenance.
		c. Test lamp defective	c. Refer to higher category of maintenance.

CHAPTER 5

ORGANIZATIONAL MAINTENANCE INSTRUCTIONS

5-1. Scope of Organizational Maintenance

The maintenance duties assigned to the organizational repairman of the camera set are listed below, together with references to paragraphs covering the specific maintenance function. The tools and test equipment required are specified in paragraph 5-2.

- a. Organizational monthly preventive maintenance checks and services chart (para 5-5).
- b. Organizational troubleshooting (para 5-6).
- c. Organizational repairs, adjustments, and replacement of parts (para 5-7 through 5-10).

5-2. Tools, Materials, and Test Equipment Required

In addition to the materials required for operator's maintenance (para 4-2), the items given below are required for organizational maintenance:

- a. Tool Kit, Photographic Repairman TK-77/GF.
- b. Multimeter AN/USM-223.

5-3. Organizational Preventive Maintenance

a. Organizational preventive maintenance is the systematic care and servicing of equipment to maintain it in serviceable condition, prevent breakdowns, and assure maximum operational capability. Preventive maintenance is the responsibility of all personnel concerned with the equip-

ment and includes inspection, testing, and repair or replacement of parts that inspection and tests indicate would probably fail before the next scheduled periodic service. Organizational preventive maintenance checks and services of the camera set are made at monthly intervals unless otherwise directed by the commanding officer. The preventive maintenance checks and services should be scheduled concurrently with the operator's daily (para 4-5) and weekly (para 4-6) preventive maintenance checks and services.

b. Maintenance forms and records to be used and maintained on this equipment are specified in TM 38-750.

5-4. Organizational Monthly Preventive Maintenance

Perform the maintenance functions indicated in the monthly preventive maintenance checks and services chart (para 5-5) once each month. A month is defined as approximately 30 calendar days of 8-hour-per-day operation. If the equipment is operated 16 hours a day, the monthly preventive maintenance checks and services should be performed at 15-day intervals. Adjustments of the maintenance interval must be made to compensate for any unusual operating conditions. Equipment maintained in a *standby* condition must have monthly preventive maintenance checks and services performed on it. Equipment in *limited storage* does not require monthly preventive maintenance.

5-5. Organizational Monthly Preventive Maintenance Checks and Services Chart

a. Camera.

<i>Sequence No.</i>	<i>Item to be inspected</i>	<i>Procedure</i>	<i>References</i>
1	Camera lens assemblies bayonet mount.	Press lens locking lever; rotate lens counterclockwise and lift out. Place red dots together; hold lens against flange while turning lens clockwise. Check to see that lens does not bind, and snaps lens locking lever in place; test normal, wide-angle, and telephoto lens assemblies.	Para 3-8, 3-9, and 3-10.

Sequence No.	Item to be inspected	Procedure	Reference
2	Film winding lever -----	Load film in camera. Wind film winding lever counterclockwise. Check to see that rewind knob turns, film advances one frame, exposure counter advances one graduation, and shutter cocks. Check to see that film winding lever snaps back to normal position when released.	Para 3-8, 3-9, and 3-10.
3	Rewind knob -----	Press in rewind button, lift rewind crank, and turn it clockwise; check to see that film winds into film cartridge without scraping or binding. Check to see that rewind button snaps out to normal position when film winding lever is operated. Lift up rewind knob to check detent operation.	
4	Back cover -----	Shift back cover lock release (fig.3-3) to left and press it in; check to see that back cover snaps open. Check condition of hinge, film pressure plate, and springs. Close back cover; check to see that it fits tightly all around and locks securely in place. Check to see that exposure counter index returns to the beginning when back cover is opened.	
5	Focusing scale -----	Sight an object through finder assembly and turn focusing scale until focus is seen sharply. Check focusing scale for smooth operation; make sure infinity mark lines up with index mark when focusing scale is turned fully clockwise to stop.	
6	Film speed adjusting ring-----	Turn film speed adjusting ring to various positions; make sure that film speed adjustment ring stops with detent action on desired position. Check each speed by winding lever and pressing shutter release button. Set shutter to B, wind film advance lever, and press shutter release button; make sure that shutter remains open as long as shutter release button is held down. Check to see that shutter closes when shutter release button is released. Check film speed adjusting ring for binding or sticking when setting speeds.	Para 3-1.
7	Aperture index -----	Set aperture index to each f/stop; make sure that aperture index has detent action for each f/stop. Test f/stop openings; observe diameter of opening when looking through lens (camera back open), and operate shutter at a slow speed. Make sure that size of opening varies with different settings.	Para 3-1.
8	ASA film speed indicator -----	Pull up film speed adjusting ring; check each position of ASA film speed indicator. Check to see that ASA film speed indicator locks in each position when film speed adjusting ring is released. Check for binding or sticking of ASA film speed indicator when checking positions.	Para 3-1b.
9	Exposure meter operation -----	Set ASA film speed indicator and shutter speedscale for existing conditions; view through finder assembly (lens cap removed), and direct camera at various light levels. Make sure that meter needle moves and indicates change in light levels. Turn shutter speed scale while viewing through eyepiece; check to see that meter needle varies with shutter speed scale setting.	Para 3-8 and 3-9.
10	Battery -----	Remove battery cover and lift out battery; check condition of battery and contacts. Replace battery; observe polarity and replace battery cover.	

b. Flashgun.

Sequence No.	Item to be inspected	Procedure	References
1	Flashgun -----	Install flashgun on camera; connect flashgun cable to flashgun and camera flash socket. Check to see that locking knob secures flashgun firmly in camera accessory shoe. Check to see that plug and flash connection ends of flashgun cable fit firmly with good electrical connection.	Para 3-9.

Sequence No.	Item to be inspected	Procedure	References
2	Folding reflector assembly -----	Open reflector and hook in desired slot; check for damaged leaves and defective surface. Tilt folding reflector assembly to its other positions; check to see that detent action holds folding reflector assembly firmly in place.	
3	Lamp socket -----	Insert bayonet, miniature bayonet, or all glass base flashlamp; check to see that they can be easily installed and held firmly in lamp socket.	
4	Bulb ejector -----	Insert a flashbulb in lamp socket. Press bulb ejector; make sure that bulb ejector operates easily and flashbulb is ejected.	
5	TEST button -----	Insert a flashbulb in lamp socket and press TEST button; check to see that test lamp flashes.	

5-6. Organizational Troubleshooting

a. Organizational Troubleshooting Information. The troubleshooting charts (b(1) and (2) below) are furnished as an aid in localizing trouble in the camera set. Only those corrective measures that the organizational maintenance man can perform are given. If the corrective measure suggested does not restore normal equipment performance, troubleshooting is required by a photographic maintenance man at a higher category of maintenance. Note on the repair tag what corrective measures were taken, and refer the equipment to

the next higher category of maintenance for repair. Before the troubleshooting chart is used, examine the repair tag to see whether the trouble has been sectionalized by the operator. If there has been no sectionalization, inspect the equipment for obvious defects before attempting to operate it.

b. Organizational Troubleshooting Chart. The chart below lists the trouble symptom, the probable trouble, and the corrective measures that can be performed by organizational maintenance personnel.

(1) Camera.

Item No.	Trouble symptom	Probable trouble	Checks and corrective measures
1	No exposure -----	a. Shutter defective ----- b. Film improperly loaded in camera ---	a. Refer to higher category of maintenance. b. Properly load film in camera (para 3-3).
2	Improper exposures-----	a. Exposure meter defective ----- b. Battery exhausted ----- c. ASA film speed indicator improperly set. d. Lens not in locked position ----- e. Improper shutter speed, and f/stop values selected.	a. Refer equipment to higher category of maintenance. b. Replace battery (para 5-8). c. Use correct ASA speed when setting ASA film speed indicator. d. Turn lens clockwise until lens is locked by lens lock release lever. e. Use exposure meter or chart to get proper values.
3	No exposures when using flashbulb --	a. Shutter speed and f/stop improperly set. b. Defective flash socket or shutter -----	a. Use flash calculator and guide number. b. Refer to higher category of maintenance.
4	Film cannot be advanced -----	a. Film improperly loaded in camera, b. Film is past last exposure -----	a. had film in camera properly (para 3-3). b. Rewind film and reload with fresh film.
5	Film cannot be rewound -----	a. Rewind button not depressed ----- b. Film pulled out of film cartridge -----	a. Press rewind button firmly. b. Unload film in darkroom; return film to film cartridge.
6	Exposure counter inoperative -----	a. Exposure counter mechanism is defective. b. Back cover not completely closed ----	a. Refer to higher category of maintenance. b. Close back cover firmly until it locks.

<i>Item No.</i>	<i>Trouble symptom</i>	<i>Probable trouble</i>	<i>Checks and corrective measures</i>
7	Light-struck stuck film -----	a. Back cover not completely closed ---- b. Back cover opened before film was rewound into film cartridge. c. Defective shutter or film blind -----	a. Close back cover firmly until it locks. b. Rewind film into film cartridge before opening back cover. c. Refer to higher category of maintenance.
8	Lens will not lock in bayonet mount.	Defective bayonet mount or lens lock release lever.	Refer to higher category of maintenance.

(2) Flashgun.

<i>Item No.</i>	<i>Troubleshooting symptom</i>	<i>Probable trouble</i>	<i>Checks and corrective measures</i>
1	Flashgun inoperative -----	Shutter connecting cord open -----	Check continuity of flashgun cable; replace if necessary.
2	Flashgun flashes when inserted in lamp socket.	a. Short in flashgun cable or flashgun coupler. b. Defective shutter -----	a. Check flashgun cable and flashgun coupler for shorted condition; replace if defective. b. Refer to higher category of maintenance.
3	Lamp does not flash when TEST button is depressed.	a. Defective flashbulb ----- b. Battery exhausted ----- c. Capacitor defective ----- d. Test lamp defective -----	a. Replace flashbulb. b. Replace battery (para 5-8). c. Replace capacitor (para 5-9). d. Replace test lamp (para 5-10).

5-7. Organizational Repairs, Adjustments, and Replacement of Parts

a. Organizational maintenance includes the repair, adjustment, or replacement of parts for which the authorized tools, test equipment, and spare parts have been made available. All other items which need repair or replacement must be handled at a higher category of maintenance.

b. When electrical components are replaced, observe the polarity of components and tag all leads to insure proper reassembly.

a. Battery Replacement.

- (1) Raise the folding reflector assembly.
- (2) Press the cover release and lift off the housing assembly cover.
- (3) Lift out the battery.
- (4) Install a new battery in the housing assembly (check the polarity before inserting the battery).
- (5) Replace the housing assembly cover.

b. Capacitor Replacement.

- (1) Raise the folding reflector assembly.
- (2) Press the cover release and lift off the housing assembly cover.
- (3) Lift out the capacitor.
- (4) Install a new capacitor in the housing assembly (check the polarity before inserting the capacitor).
- (6) Replace the housing assembly cover.

5-8. Replacement of Camera Battery

(fig. 6-1)

Install a new battery in the camera as follows:

- a. Unscrew the battery compartment cover on the camera baseplate.
- b. Remove the battery from the battery compartment.
- c. Install the new battery (observe the polarity).
- d. Screw on the battery compartment cover.
- e. Test the action of the exposure meter.

5-10. Replacement of Flashgun Test Lamp

(fig. 5-2-and 5-3)

Replace the flashgun test lamp as follows.

- u. Raise the folding reflector assembly.
- b. Press the cover release and lift off the housing assembly cover.
- c. Remove the battery and the capacitor.

5-9. Replacement of Flashgun Battery or Capacitor

(fig. 6-2 and 5-3)

Replace the flashgun battery (a below) or the capacitor (b below) as follows:

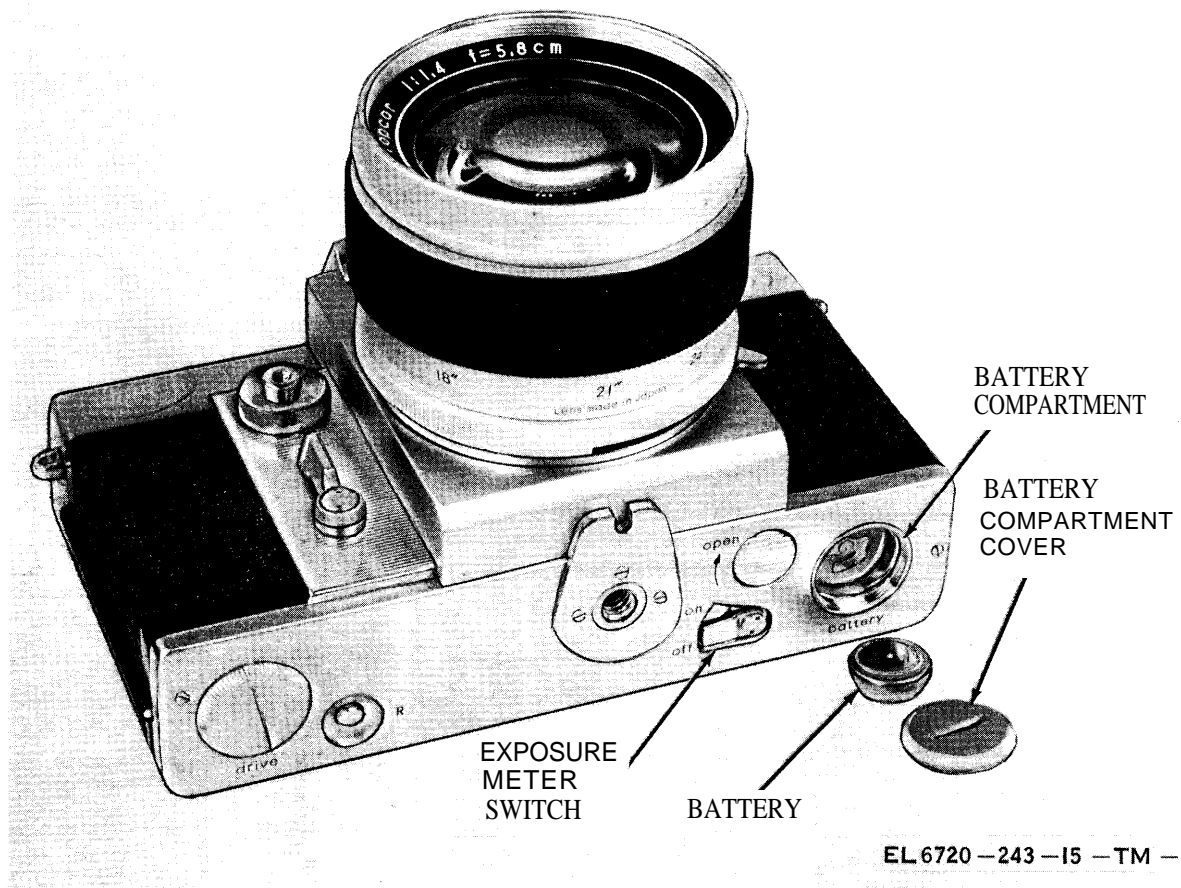

Figures 5-1. Camera with battery and battery compartment cover removed.

- d. Unscrew the retaining screw on the test lamp cover.
- e. Carefully lift out the test lamp cover.
- f. Unscrew the TEST button spring holder screw; remove the spring holder and the spring.
- g. Remove the test lamp from the TEST button.
- h. Install a tested lamp in the TEST button.
- i. Replace the TEST button spring and the spring holder; secure them with the TEST button spring holder screw.
- j. Replace the test lamp cover (be carefully to avoid damage to the wiring).
- k. Secure the test lamp cover with the test lamp cover retaining screw.
- l. Replace the battery and the capacitor.
- m. Replace the housing assembly cover.

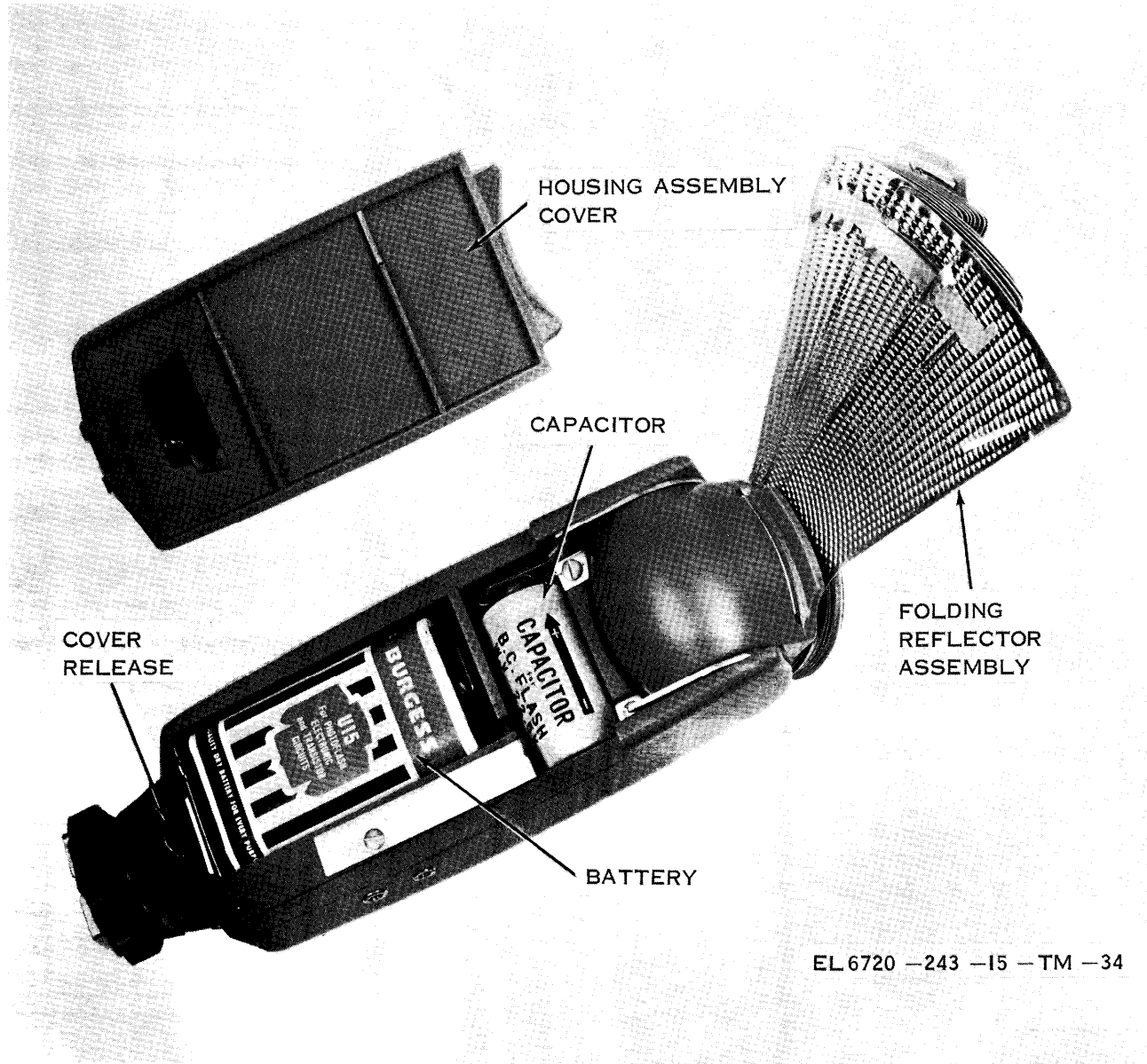

Figure 5-2. Flashgun, housing assembly cover removed.

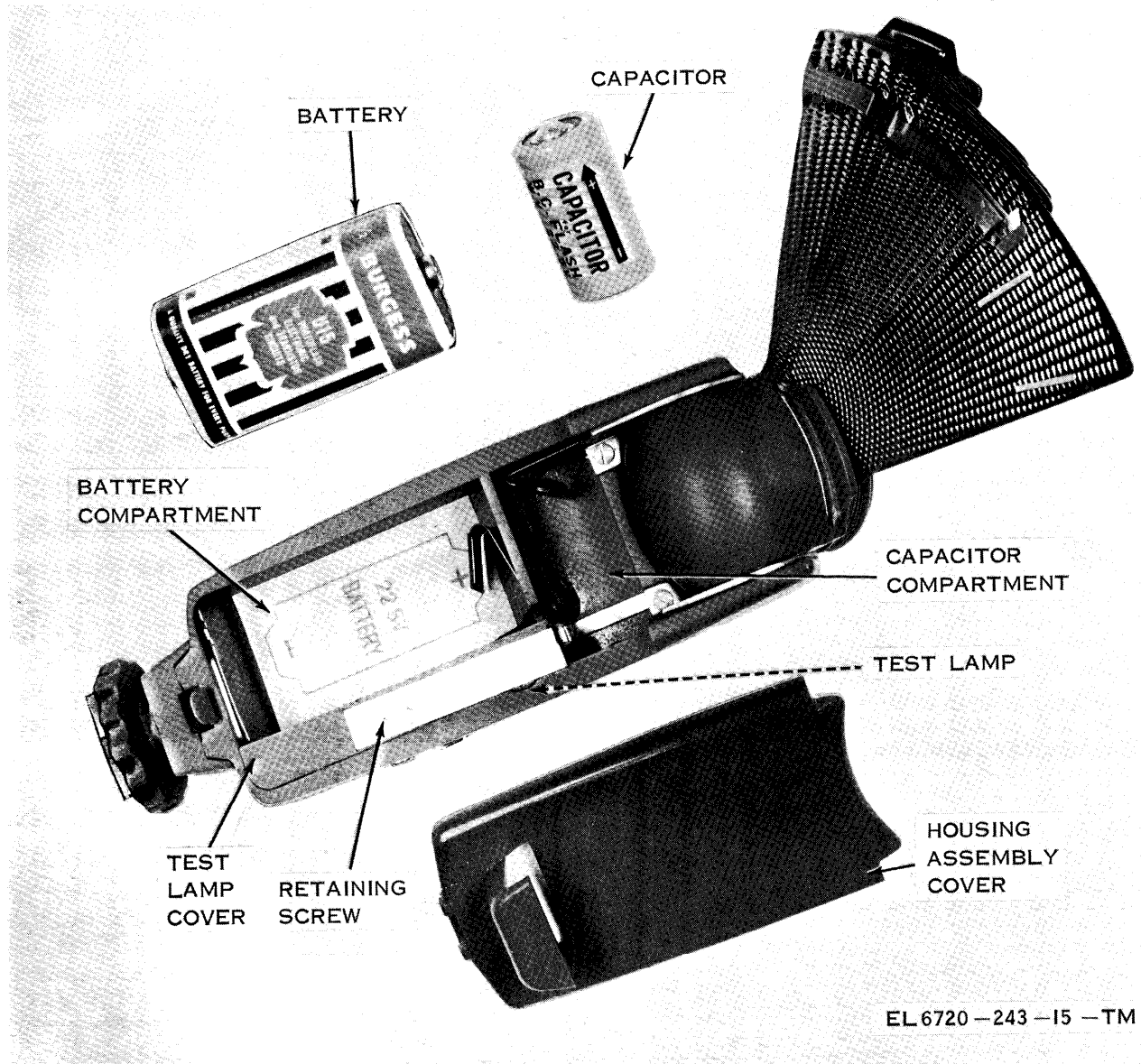

Figure 5-3. Flashgun, partially disassembled.

CHAPTER 6

SHIPMENT AND LIMITED STORAGE AND DEMOLITION TO PREVENT ENEMY USE

Section I. SHIPMENT AND LIMITED STORAGE

6-1. Disassembly of Camera Set

All disassembly of the camera set for shipment and limited storage may be done by the operator. For shipment or limited storage, the equipment should be returned to the carrying case, as described in paragraph 3-12. The shutter should be tripped, and all exposed film should be removed from the camera and forwarded for processing.

6-2. Repacking Camera Set for Shipment or Limited Storage

The exact procedure for repacking for shipment or limited storage depends on the material available and the conditions under which the equipment is to be shipped or stored. The procedures given below may be used, or varied, as necessary. Refer to figure 2-1 and perform the procedures in the order indicated.

a. Check to be sure that the procedures given in paragraph 4-7 have been performed.

b. Inventory all components; check the equipment against the table of components (para 1-6).

c. Pack the components as follows:

(1) Check to see that one of the lens assemblies (with attached front lens cap) is installed on the camera component.

(2) Place the camera component (with attached lens assembly and front lens caps) in the carrying case, as shown in figure 2-1.

(3) Place the other two lens assemblies, the flashgun, and minor components in their respective compartments in the carrying case.

(4) Close the carrying case cover and fasten the hinged fasteners.

(5) Insert the carrying case into the fiberboard cartons.

(6) Close the tops of the fiberboard cartons and seal them with gummed paper.

Section II. DEMOLITION OF MATERIEL TO PREVENT ENEMY USE

6-3. Authority for Demolition

Demolition of the equipment will be accomplished only upon the order of the commander. Use the destruction procedures given in paragraph 6-4 to prevent further use of the equipment.

6-4. Methods of Destruction

a. If complete destruction of the equipment cannot be accomplished in the time available, destroy the components in the order given below.

- (1) Lens assemblies.
- (2) Camera.
- (3) Flashgun.
- (4) Filter and film cartridges.

(5) Carrying case.

(6) Remaining minor components.

b. Use any of the following methods to destroy the equipment:

(1) *Smash*. Smash the lens assemblies, the camera component, the flashgun, the filter, the lens shade, the minor components, and the carrying case.

(2) *Cut*. Cut the carrying case and the air syringe.

WARNING

Be extremely careful with explosives and incendiary devices. Use these items only when the need is urgent.

TM 11-6720-243-15

(3) *Burn*. Burn the film cartridges, the manuals, and the carrying case.

(4) *Bend*. Bend the camera body, the lens assemblies, and the flashgun.

(5) *Bury*. Bury or scatter destroyed parts in slit trenches or foxholes, or throw them into streams or lakes.

APPENDIX A
REFERENCES

Following is a list of applicable references available to the operator and maintenance personnel of Camera Set, Still Picture KS-99B.

- DA Pam 310-4 - - - - - Index of Technical Manuals, Technical Bulletins, Supply Manuals (types 7, 8, and 9), Supply Bulletins, and Lubrication Orders.
- DA Pam 310-7 - - - - - U.S. Army Equipment Index of Modification Work Orders.
- SB 11-573 - - - - - Painting and Preservation Supplies Available for Field Use for Electronics Command Equipment.
- SB 38-100 - - - - - Preservation, Packaging, and Packing Materials, Supplies and Equipment Used by the Army.
- TB 746-10 - - - - - Field Instructions for Painting and Preserving Electronics Command Equipment.
- TM 9-213 - - - - - Painting Instructions for Field Use.
- TM 11-401 - - - - - Elements of Signal Photography.
- TM 38-750 - - - - - The Army Maintenance Management System (TAMMS).

APPENDIX B

**BASIC ISSUE ITEMS (BIIL) AND ITEMS TROOP
INSTALLED OR AUTHORIZED LIST (ITIAL)**

Section I. INTRODUCTION

B-1. Scope

This appendix list basic issue items and items troop installed or authorized required by the crew/operator for installation, operation, and maintenance of Camera Set, Still Picture KS-99B.

B-2. General

This Basic Issue Items and Items Troop Installed or Authorized List is divided into the following sections:

a. Basic Issue Items List-Section II. A list, in alphabetical sequence, of items which are furnished with, and which must be turned in with the end item.

b. Items Troop Installed or Authorized List-Section III. A list, in alphabetical sequence of items which, at the discretion of the unit commander, may accompany the end item, but are not subject to be turned in with the end item.

B-3. Explanation of Columns

The following provides an explanation of columns found in the tabular listings:

a. Illustration. Not applicable.

b. Federal Stock Number. Indicates the Federal stock number assigned to the item and will be used for requisitioning purposes.

c. Part Number. Indicates the primary number used by the manufacturer (individual, company, firm, corporation, or Government activity), which controls the design and characteristics of the item by means of its engineering drawings, specifications standards, and inspection requirements, to identify an item or range of items.

d. Federal Supply Code for Manufacturer (FSCM). The FSCM is a 5-digit numeric code used to identify the manufacturer, distributor, or Government agency, etc., and is identified in SB 708-42.

e. Description. Indicates the Federal item name and a minimum description required to identify the item.

f. Unit of Measure (U/M). Indicates the standard of basic quantity of the listed item as used in performing the actual maintenance function. This measure is expressed by a two-character alphabetical abbreviation, (e.g., ea, in., pr, etc.). When the unit of measure differs from the unit of issue, the lowest unit of issue that will satisfy the required units of measure will be requisitioned.

g. Quantity Furnished with Equipment (Basic Issue Items Only). Indicates the quantity of the basic issue item furnished with the equipment.

h. Quantity Authorized (Items Troop Installed or Authorized Only). Indicates the quantity of the item authorized to be used with the equipment.

Section II. BASIC ISSUE ITEMS LIST

(1) Illustration		(2) Federal Stock Number	(3) Part Number	(4) FSCM	(5) Description	Usable on Code	(6) Unit of Meas	(7) Qty Furn With Equip
(A) Fig. No.	(B) Item No.							
		6720-832-4768	BT-321	07055	CASE PHOTOGRAPHIC EQUIPMENT		EA	1
			BT-126	07055	LENS CAP		EA	1
			127	07055	LENS CAP		EA	1
			BT-128	07055	LENS CAP		EA	1

Section III. ITEMS TROOP INSTALLED OR AUTHORIZED LIST

(1) Federal Stock Number	(2) Part Number	(3) FSCM	(4) Description Usable on Code	(5) Unit of Meas	(6) Qty Auth
6710-086-7700	313049	06650	BRUSH LENS, CAMEL	EA	1
6710-356-6334	22166	06650	SYRINGE RUBBER	EA	1

APPENDIX C

MAINTENANCE ALLOCATION

Section I. INTRODUCTION

C-1. General

This appendix provides a summary of the maintenance operations covered in the equipment literature for the KS-99B.

It authorizes categories of maintenance for specific maintenance functions on repairable items and components and the tools and equipment required to perform each function. This appendix may be used as an aid in planning maintenance operations.

C-2. Maintenance Functions

Maintenance functions will be limited to and defined as follows:

- a.* INSPECT. To determine serviceability of an item by comparing its physical, mechanical, and electrical characteristics with established standards.
- b.* TEST. To verify serviceability and to detect incipient electrical or mechanical failure by use of special equipment such as gages, meters, etc. This is accomplished with external test equipment and does not include operation of the equipment and operator type tests using internal meters or indicating devices.
- c.* SERVICE. To clean, to preserve, to charge, and to add fuel, lubricants, cooling agents, and air. If it is desired that elements, such as painting and lubricating, be defined separately, they may be so listed.
- d.* ADJUST. To rectify to the extent necessary to bring into proper operating range.
- e.* ALIGN. To adjust two or more components or assemblies of an electrical or mechanical system so that their functions are properly synchronized. This does not include setting the frequency control knob of radio receivers or transmitters to the desired frequency.
- f.* CALIBRATE. To determine the corrections to be made in the readings of instruments or test equipment used in precise measurement. Consists of the comparison of two instruments, one of which is a certified standard of known accuracy, to detect and adjust any discrepancy in the accuracy of the instrument being compared with the certified standard.
- g.* INSTALL. To set up for use in operational environment such as an encampment, site, or vehicle.
- h.* REPLACE. To replace unserviceable items with serviceable like items.
- i.* REPAIR. To restore an item to serviceable condition through correction of a specific failure or unserviceable condition. This function includes, but is not limited to welding, grinding, riveting, straightening, and replacement of parts other than the trial and error replacement of running spare type items such as fuses, lamps, or electron tubes.
- j.* OVERHAUL. Normally, the highest degree of maintenance performed by the Army in order to minimize time work in process is consistent with quality and economy of operation. It consists of that maintenance necessary to restore an item to completely serviceable condition as prescribed by maintenance standards in technical publications for each item of equipment. Overhaul normally does not return an item to like new, zero mileage, or zero hour condition.
- k.* REBUILD. The highest degree of materiel maintenance. It consists of restoring equipment as nearly as possible to new condition in accordance with original manufacturing standards. Rebuild is performed only when required by operational considerations or other paramount factors and then only at the depot maintenance category. Rebuild reduces to zero the hours or miles the equipment, or component thereof, has been in use.
- l.* SYMBOLS. The uppercase letter placed in the

appropriate column indicates the lowest level at which that particular maintenance function is to be performed.

C-3. Explanation of Format

a. *Column 1, group number.* Not applicable.

b. *Column 2, functional group.* Column 2 lists the noun names of components, assemblies, subassemblies and modules on which maintenance is authorized.

c. *Column 3, maintenance functions.* Column 3 lists the maintenance category at which performance of the specific maintenance function is authorized. Authorization to perform a function at any category also includes authorization to perform that function at higher categories. The codes used represent the various maintenance categories as follows:

Code	<i>Explanation</i>
C-----	Operator/Crew
O-----	Organizational Maintenance
F-----	Direct Support Maintenance
H-----	General Support Maintenance
D-----	Depot Maintenance

d. *Column 4, tools and test equipment.* Column 4 specifies, by code, those tools and test equipment required to perform the designated function. The

numbers appearing in this column refer to specific tools and test equipment which are identified in table I.

e. *Column 5, Remarks.* Self-explanatory.

C-4. Explanation of Format of Table I, Tool and Test Equipment Requirements

The column in Table I, Tool and Test Equipment Requirements are as follows:

a. *Tools and Equipment.* The numbers in this column coincide with the numbers used in the tools and equipment column of the Maintenance Allocation Chart. The numbers indicate the applicable tool for the maintenance function.

b. *Maintenance Category.* The codes in this column indicate the maintenance category normally allocated the facility.

c. *Nomenclature.* This column lists tools, test, and maintenance equipment required to perform the maintenance functions.

d. *Federal Stock Number.* This column lists the Federal stock number of the specific tool or test equipment.

e. *Tool Number.* Not used.

SECTION II. MAINTENANCE ALLOCATION CHART

MAINTENANCE ALLOCATION CHART														
GROUP NUMBER	COMPONENT ASSEMBLY NOMENCLATURE	MAINTENANCE FUNCTIONS										TOOLS AND EQUIPMENT	REMARKS	
		INSPECT	TEST	SERVICE	ADJUST	ALIGN	CALIBRATE	INSTALL	REPLACE	REPAIR	OVERHAUL			REBUILD
	CAMERA SET, STILL PICTURE KS-99B	C	C		O				O				3,4	Preventive maintenance: clean, inspect for broken parts. Mechanical operation: replace battery continuity motor system. Replace battery at least once a year. Battery does not deteriorate slowly; a sudden drop-off of voltage occurs. Replace assemblies as required.
	CAMERA BODY, KS-99B	C	C		O				O	D		D	1 thru 6	Replace as required
	LENS, STANDARD, 35 MM	C	C		O				O	D		D	4 1 thru 6	Replace as required.
	FILTER Y2 (NORMAL LENS)	C	C						O				4	Replace as required.
	LENS HOOD (NORMAL)	C	C		O				O				4	Replace as required.
	PRISM ASSEMBLY	C	C						O	D		D	1 thru 6	Replace as required.
	LENS, TELEPHOTO, 35 MM	C	C		O				O	D		D	4 1 thru 6	Replace as required.
	FILTER Y2 (TELEPHOTO AND WIDE ANGLE)	C	C						O				4	Replace as required.

TABLE I. TOOL AND TEST EQUIPMENT REQUIREMENTS

TOOL AND TEST EQUIPMENT REQUIREMENTS				
TOOLS AND EQUIPMENT	MAINTENANCE CATEGORY	NOMENCLATURE	FEDERAL STOCK NUMBER	TOOL NUMBER
		KS -99B (cont)		
1	D	EXPOSURE METER TESTER	6760-832-4467	
2	D	LENS REMOVING TOOL	6720-832-4838	
3	O,D	MULTIMETER AN/USM-223	6625-999-7465	
4	O,D	TOOL KIT, PHOTOGRAPHIC REPAIR TK-77/GF	5180-752-9068	
5	D	TOOL KIT, PHOTOGRAPHIC REPAIR TK-109/GF	5180-856-9653	
6	D	WRENCH, SPANNER	5120-832-6171	

APPENDIX D
ORGANIZATIONAL, DIRECT SUPPORT, GENERAL SUPPORT, AND DEPOT
MAINTENANCE REPAIR PARTS AND SPECIAL TOOLS LIST

Section I. INTRODUCTION

D-1. Scope

This appendix lists repair parts and special tools required for the performance of organizational, direct support, general support, and depot maintenance of the KS-99B.

D-2. General

This Repair Parts and Special Tools List is divided into the following sections:

a. Prescribed Load Allowance (PLA) —Section II. A composite listing of repair parts, special tools, test and support equipment having quantitative allowances for initial stockage at the organizational level.

b. Repair Parts—Section III. A list of repair parts authorized for the performance of maintenance at the organizational level.

c. Special Tools, Test and Support Equipment —Section IV. Not applicable.

d. Repair Parts Section V. A list of repair parts authorized for the performance of maintenance at the direct support, general support, and depot level.

e. Special Tools, Test and Support Equipment —Section VI. Not applicable.

D-3. Explanation of Columns

The following provides an explanation of columns in the tabular lists.

a. Source, Maintenance, and Recoverability Codes (SMR).

(1) Source code indicates the selection status and source for the list item. Source codes are:

Code	Explanation
P	—Repair parts which are stocked in or supplied from the GSA/DSA, or Army supply system and authorized for use at indicated maintenance categories.

code	Explanation
P2	—Repair parts which are procured and stocked for insurance purposes because the combat or military essentiality of the end item dictates that a minimum quantity be available in the supply system.
P9	—Assigned to items which are NSA design controlled: unique repair parts, special tools, test, measuring and diagnostic equipment, which are stocked and supplied by the Army COMSEC logistic system, and which are not subject to the provisions of AR 380-41.
P10	—Assigned to items which are NSA design controlled: special tools, test, measuring and diagnostic equipment for COMSEC support, which are accountable under the provisions of AR 380-41, and which are stocked and supplied by the Army COMSEC logistic system.
M	—Repair parts which are not procured or stocked, but are to be manufactured in indicated maintenance levels.
A	—Assemblies which are not procured or stocked as such, but are made up of two or more units. Such component units carry individual stock numbers and descriptions, are procured and stocked separately and can be assembled to form the required assembly at indicated maintenance categories.
x	—Parts and assemblies which are not procured or stocked and the mortality of which normally is below that of the applicable end item or component. The failure of such part or assembly should result in retirement of the end item from the supply system.
X1	—Repair parts which are not procured or stocked. The requirement for such items will be filled by use of the next higher assembly or component.
X2	—Repair parts which are not stocked. The indicated maintenance category requiring such repair parts will attempt to obtain same through cannibalization. Where such repair parts are not obtainable through cannibalization, requirements will be requisitioned, with accompanying justification, through normal supply channels.

<i>Code</i>	<i>Explanation</i>
G	—Major assemblies that are procured with PEMA funds for initial issue only as exchange assemblies at DSU and GSU level. These assemblies will not be stocked above DS and GS level or returned to depot supply level.

(2) Maintenance code indicates the lowest category of maintenance authorized to install the listed item. The maintenance level codes are:

<i>Code</i>	<i>Explanation</i>
C-----	Operator/Crew
O-----	Organizational Maintenance
F-----	Direct support maintenance
H-----	General support maintenance
D-----	Depot maintenance

(3) Recoverability code indicates whether unserviceable items should be returned for recovery or salvage. Items not coded are expendable. Recoverability codes are:

<i>Code</i>	<i>Explanation</i>
R	—Repair parts and assemblies that are economically repairable at DSU and GSU activities and normally are furnished by supply on an exchange basis.
s	—Repair parts and assemblies which are economically repairable at DSU and GSU activities and which normally are furnished by supply on an exchange basis. When items are determined by a GSU to be uneconomically repairable, they will be evacuated to a depot for evaluation and analysis before final disposition.
T	—High dollar value recoverable repair parts which are subject to special handling and are issued on an exchange basis. Such repair parts normally are repaired or overhauled at depot maintenance activities.
u	—Repair parts specifically selected for salvage by reclamation units because of precious metal content, critical materials, or high dollar value reusable casings or castings.

b. Federal Stock Number. Indicates the Federal stock number assigned to the item and will be used for requisitioning purposes.

c. Description. Indicates the Federal item name and any additional description of the item required. A part number or other reference number is followed by the applicable five-digit Federal supply code for manufacturers in parentheses.

d. Unit of Measure (U/M). A two character alphabetic abbreviation indicating the amount or quantity of the item upon which the allowances are based, e.g., ft, ea, pr, etc.

e. Quantity Incorporated in Unit. Indicates the quantity of the item used in the KS-99B. A "V"

appearing in this column in lieu of a quantity indicates that a definite quantity cannot be indicated (e.g., shims, spacers, etc).

f. 15-Day Organizational Maintenance Allowances.

(1) The allowance columns are divided into four subcolumns. Indicated in each subcolumn opposite the first appearance of each item is the total quantity of items authorized for the number of equipments supported. Subsequent appearances of the same item will have the letters "REF" in the allowance columns. Items authorized for use as required but not for initial stockage are identified with an asterisk in the allowance column.

(2) The quantitative allowances for organizational level of maintenance represents one initial prescribed load for a 15-day period for the number of equipments supported. Units and organizations authorized additional prescribed loads will multiply the number of prescribed loads authorized by the quantity of repair parts reflected in the appropriate density column to obtain the total quantity of repair parts authorized.

(3) Organizational units providing maintenance for more than 100 of these equipments shall determine the total quantity of parts required by converting the equipment quantity to a decimal factor by placing a decimal point before the next to last digit of the number to indicate hundredths, and multiplying the decimal factor by the parts quantity authorized in the 51-100 allowance column. Example, authorized allowance for 51-100 equipments is 12; for 140 equipments multiply 12 by 1.40 or 16.80 rounded off to 17 parts required.

(4) Subsequent changes to allowances will be limited as follows: No change in the range of items is authorized. If additional items are considered necessary, recommendation should be forwarded to Commanding General, U.S. Army Electronics Command, ATTN: AMSEL-ME-NMP-EM, Fort Monmouth, N.J. 07703, for exception or revision to the allowance list. Revisions to the range of items authorized will be made by the USAECOM National Maintenance Point based upon engineering experience, demand data, or TAERS information.

g. 30-Day DS/GS Maintenance Allowances.

NOTE

Allowances in GS Column are for GS maintenance only.

(1) The allowance columns are divided into

three subcolumns. Indicated in each subcolumn, opposite the first appearance of each item, is the total quantity of items authorized for the number of equipments supported. Subsequent appearances of the same item will have the letters "REF" in the applicable allowance columns. Items authorized for use as required but not for initial stockage are identified with an asterisk in the allowance column.

(2) The quantitative allowances for DS/GS levels of maintenance will represent initial stockage for a 30-day period for the number of equipments supported.

(3) Determination of the total quantity of parts required for maintenance of more than 100 of these equipments can be accomplished by converting the equipment quantity to a decimal factor by placing a decimal point before the next to last digit of the number to indicate hundredths, and multiplying the decimal factor by the parts quantity authorized in the 51-100 allowance column. Example, authorized allowance for 51-100 equipments is 40; for 150 equipments multiply 40 by 1.50 or 60 parts required.

h. 1-Year Allowances Per 100 Equipments/Contingency Planning Purposes. Indicates opposite the first appearance of each item the total quantity required for distribution and contingency planning purposes. The range of items indicates total quantities of all authorized items required to provide for adequate support of 100 equipments for one year.

i. Depot Maintenance Allowance Per 100 Equipments. Indicates opposite the first appearance of each item the total quantity authorized for depot maintenance of 100 equipments. Subsequent appearances of the same item will have the letters "REF" in the allowance column. Items authorized for use as required but not for initial stockage are identified with an asterisk in the allowance column.

j. Illustration.

(1) *Figure number.* Indicates the figure number of the illustration in which the item is shown.

(2) *Item number.* Not applicable.

D-4. Special Information

Repair parts mortality is computed from failure rates derived from experience factors with the individual parts in a variety of equipments. Variations in the specific application and periods of use of electronics equipment, the fragility of electronic piece parts, plus intangible material and quality factors intrinsic to the manufacture of electronic parts, do not permit mortality to be based on hours of end item use. However, long periods of continuous use under adverse conditions are likely to increase repair parts mortality.

D-5. Federal Supply Code for Manufacturers

<i>Code</i>	<i>Manufacturer</i>
06650 -----	Bell and Howell Co.
07055 -----	Charles Beseler Co.
96906-----	Military Standards

SECTION II. PRESCRIBED LOAD ALLOWANCE

(1) FEDERAL STOCK NUMBER	(2) DESCRIPTION USABLE ON CODE	(3) 15-DAY ORG. MAINT. ALLOWANCE			
		(a) 1-5	(b) 6-20	(c) 21-50	(d) 51-100
6640-393-2090	TISSUE LENS: MIL-P-40-TYPEL; (96906)				2
	LENS CAP: BT126; (07055)				2
	LENS CAP: 127; (07055)				2
	LENS CAP: BT-128; (07055)				2

SECTION III. REPAIR PARTS FOR ORGANIZATIONAL MAINTENANCE

(1) SMR CODE	(2) FEDERAL STOCK NUMBER	(3) DESCRIPTION Reference Number & Mfr Code	(4) UNIT OF MEAS	(5) QTY INC IN UNIT	(6) 15-DAY ORGANIZATIONAL MAINTENANCE ALW				(7) ILLUSTRATIONS	
					(a) 1-5	(b) 6-20	(c) 21-50	(d) 51-100	(a) FIG NO.	(b) ITEM NO. OR REFERENCE DESIGNATION
	6720-935-3860	CAMERA SET, STILL PICTURE KS-99B: BT-400; (07055) (This item is nonexpendable)							1-1	
P-0	6760-487-4134	ADAPTER, SHOE FLASH: BT-69; (07055)	EA	1	*	*	*	*	1-1	
P-0	6720-484-3729	BODY CAMERA, STILL PICTURE: BT-301; (07055)	EA	1	*	*	*	*	1-1	
P-0	6710-086-7700	BRUSH LENS CAMEL: 313049; (06650)	EA	1	*	*	*	*	1-1	
P-0	6720-484-0930	CAMERA, STILL PICTURE KE-53A	EA	1	*	*	*	*	1-1	
P-0	7930-392-9751	CLEANER LENS: 04217; (06650)	EA	1	*	*	*	*	1-1	
P-0	6760-486-8328	FILTER LIGHT PHOTOGRAPHIC LENS: BT-21-Y2; (07055)	EA	1	*	*	*	*	1-1	
P-0	6760-832-4757	FILTER, LIGHT PHOTOGRAPHIC LENS: BT-73-Y2; (07055)	EA	1	*	*	*	*	1-1	
P-0	6760-937-9968	FLASH GUN PHOTOGRAPHIC: BT-220; (07055)	EA	1	*	*	*	*	1-1	
P-0	6720-487-4135	LENS CAMERA, GENERAL PHOTOGRAPHIC: BT-345; (07055)	EA	1	*	*	*	*	1-1	
P-0	6760-487-4136	LENS, CAMERA, GENERAL PHOTOGRAPHIC: BT-335; (07055)	EA	1	*	*	*	*	1-1	
P-0	6760-487-4137	LENS, CAMERA GENERAL PHOTOGRAPHIC: BT-375; (07055)	EA	1	*	*	*	*	1-1	
P-0		LENS CAP: BT-126; (07055)	EA	2	*	*	*	*	1-1	
P-0		LENS CAP: 127; (07055)	EA	1	*	*	*	*	1-1	
P-0		LENS CAP: BT-128; (07055)	EA	2	*	*	*	*	1-1	
P-0	6760-485-9701	LENS HOOD: BT-17C; (07055)	EA	1	*	*	*	*	1-1	
P-0	6760-485-9702	LENS HOOD: BT-53; (07055)	EA	1	*	*	*	*	1-1	
P-0	6710-356-6334	SYRINGE, RUBBER: 22166; (06650)	EA	1	*	*	*	*	1-1	
P-0	6640-393-2090	TISSUE LENS: MIL-P-40 TYPE 1; (96906)	EA	1	*	*	*	*	1-1	

SECTION v. REPAIR PARTS FOR DIRECT SUPPORT, GENERAL SUPPORT, AND DEPOT MAINTENANCE

(1) SMR CODE	(2) FEDERAL STOCK NUMBER	(3) DESCRIPTION REFERENCE NUMBER & MFR. CODE	(4) UNIT OF MEAS USABLE ON CODE	(5) QTY INC IN UNIT	(6) 30-DAY DS MAINT ALLOWANCE			(7) 30-DAY GS MAINT ALLOWANCE			(8) 1 YR ALW PER EQUIP CNTGTY	(9) DEPOT MAINT ALW PER 100 EQUIP	(10) ILLUSTRATIONS	
					(a)	(b)	(c)	(a)	(b)	(c)			(a)	(b)
					1-20	21-50	51-100	1-20	21-50	51-100			FIG NO.	ITEM NO. OR REFERENCE DESIGNATION
	6720-935-3860	CAMERA SET, STILL PICTURE KS-99B: BT-400; (07055) (This item is nonexpendable)											1-1	
P-O	6760-487-4134	ADAPTER, SHOE FLASH: BT-69; (07055)	EA	1	*	*	*	*	*	*	5	2	1-1	
P-O	6720-484-3729	BODY CAMERA, STILL PICTURE: BT-301; (07055)	EA	1	*	*	*	*	*	*	5	2	1-1	
P-O	6710-086-7700	BRUSH LENS CAMEL: 313049; (06650)	EA	1	*	*	*	*	*	*	5	2	1-1	
P-O-R	6720-484-0930	CAMERA, STILL PICTURE KE-53A	EA	1	*	*	*	*	*	*	5	2	1-1	
P-O	7930-392-9751	CLEANER LENS: 04217; (06650)	EA	1	*	*	*	*	*	*	5	2	1-1	
P-O	6760-486-8326	FILTER LIGHT PHOTOGRAPHIC LENS: BT-21-Y2; (07055)	EA	1	*	*	*	*	*	*	5	2	1-1	
P-O	6760-832-4757	FILTER, LIGHT PHOTOGRAPHIC LENS: BT-73-Y2; (07055)	EA	1	*	*	*	*	*	*	5	2	1-1	
P-O	6760-937-9968	FLASH GUN PHOTOGRAPHIC: BT-220; (07055)	EA	1	*	*	*	*	*	*	5	2	1-1	
P-O	6720-487-4135	LENS CAMERA, GENERAL PHOTOGRAPHIC: BT-345; (07055)	EA	1	*	*	*	*	*	*	5	2	1-1	
P-O	6760-487-4136	LENS, CAMERA, GENERAL PHOTOGRAPHIC: BT-335; (07055)	EA	1	*	*	*	*	*	*	5	2	1-1	
P-O	6760-487-4137	LENS, CAMERA GENERAL PHOTOGRAPHIC: BT-375; (07055)	EA	1	*	*	*	*	*	*	5	2	1-1	
P-O		LENS CAP: BT-126; (07055)	EA	2	*	*	2	*	2	2	12	5	1-1	
P-O		LENS CAP: 127; (07055)	EA	1	*	*	2	*	2	2	12	5	1-1	
P-O		LENS CAP: BT-128; (07055)	EA	2	*	*	2	*	2	2	12	5	1-1	
P-O	6760-485-9701	LENS HOOD: BT-170; (07055)	EA	1	*	*	2	*	*	2	8	3	1-1	
P-O	6760-485-9702	LENS HOOD: BT-53; (07055)	EA	1	*	*	2	*	*	2	8	3	1-1	
P-O	6710-356-6334	SYRINGE RUBBER: 22166; (06650)	EA	1	*	*	*	*	*	*	5	2	1-1	
P-O	6640-393-2090	TISSUE LENS: MIL-P-40-TYPE 1; (96906)	EA	1	*	2	2	*	2	2	13	6	1-1	

INDEX

	Paragraph	Page		Paragraph	Page
Accessories, camera:			Desert areas, operation -----	3-14	3-17
Focusing screens -----	1-15	1-5	Destruction-----	6-4	6-1
General -----	1-13	1-3	Disassembly of camera set-----	6-1	6-1
High magnification waist level finder ----	1-14	1-3	Dust-laden atmosphere, operation -----	3-14	3-17
Adjustments-----	5-7	5-4	Exposure reading -----	3-7	3-10
Authority for demolition-----	6-3	6-1	Flashgun:		
Battery replacement:			Battery or capacitor replacement -----	5-9	5-4
Camera -----	5-3	5-4	Controls and indicators-----	3-2	3-4
Flashgun -----	5-9	5-4	Description-----	1-9	1-3
Camera:			Operation-----	3-9	3-12
Accessories:			Teat lamp replacement-----	5-10	5-4
Focusing screens, fig. 1-2 -----	1-15	1-5	Focusing screen-----	1-15	1-5
General, fig. 1-2 -----	1-13	1-3	Forms and records-----	1-3	1-1
High magnification waist level finder, fig. 1-3 -----	1-14	1-3	General, camera accessories -----	1-13	1-3
Battery replacement -----	5-8	5-4	High magnification waist level finder ----	1-14	1-3
Changing lens, fig. 3-8 -----	3-4	3-8	Indexes of publications-----	1-2	1-1
Controls and indicators, fig. 3-1, 3-2, 3-3	3-1	3-1	Indicators, controls and:		
Description -----	1-8	1-2	Camera, fig. 3-1, 3-2, 3-3-----	3-1	3-1
Exchanging focusing screen, fig. 3-10 --	3-6	3-10	Flashgun, fig. 3-5-----	3-2	3-4
Exchanging viewfinders, fig. 3-9 -----	3-5	3-9	Loading film in camera-----	3-3	3-6
Exposure reading, fig. 3-11, 3-12 -----	3-7	3-10	Low temperature operation-----	3-13	3-17
Loading film, fig. 3-6, 3-7-----	3-3	3-6	Maintenance:		
Camera set:			Operator's:		
Authority for demolition-----	6-3	6-1	Checks and services periods -----	4-4	4-1
Checking unpacked equipment-----	2-2	2-1	Daily checks and services chart -----	4-5	4-1
Components, fig. 1-1-----	1-6	1-2	Materials required -----	4-2	4-1
Description-----	1-7	1-2	Preventive maintenance -----	4-3	4-1
Destruction-----	6-4	6-1	Scope-----	4-1	4-1
Disassembly-----	6-1	6-1	Troubleshooting chart -----	4-9	4-3
Repacking for shipment or limited storage-----	6-2	6-1	Troubleshooting Information-----	4-8	4-3
Unpacking, fig. 2-1-----	2-2	2-1	Visual inspection and cleaning -----	4-7	4-2
Capacitor replacement, flashgun-----	5-9	5-4	Weekly checks and services chart---	4-6	4-2
Characteristics, technical-----	1-5	1-1	Organizational:		
Checking unpacked equipment-----	2-2	2-1	Checks and services chart -----	5-5	5-1
Checks and services charts:			Monthly preventive maintenance ----	5-4	5-1
Daily-----	4-5	4-1	Preventive maintenance -----	5-3	5-1
Monthly-----	5-5	5-1	Repairs, adjustments, and replace- ment of parts -----	5-7	5-4
Weekly-----	4-6	4-2	Replacement of:		
Cleaning, visual inspection-----	4-7	4-2	Camera battery, fig. 5-1 -----	5-8	5-4
Components of camera set, fig. 1-1-----	1-6	1-2	Flashgun battery or capacitor, fig. 5-2, 5-3 -----	5-9	5-4
Control and indicators:			Flashgun test lamp, fig. 5-2,6-3 --	5-10	5-4
Camera, fig. 3-1, 3-2, 3-3-----	3-1	3-1	Scope-----	5-1	5-1
Flashgun, fig. 3-5-----	3-2	3-4	Tools, materials, and test equipment required-----	5-2	5-1
Demolition, authority-----	6-3	6-1	Troubleshooting-----	5-6	5-3
Description of:			Methods of destruction-----	6-4	6-1
Camera, fig. 3-1, 3-2,3-3-----	1-8	1-2	Minor components, description, fig. 1-1 --	1-12	1-3
Camera set, fig. 1-1-----	1-7	1-2			
Flashgun, fig. 3-4-----	1-9	1-3			
Minor components -----	1-12	1-3			
Telephoto lens -----	1-10	1-3			
Wide-angle lens -----	1-11	1-3			

	Paragraph	Page		Paragraph	Page
Operation under:			Records, forms and-----	1-3	1-1
Unusual conditions:			Repacking camera set for shipment or		
Desert areas or dust laden atmosphere	3-14	3-17	limited storage-----	6-2	6-1
Low temperatures-----	3-13	3-17	Repairs-----	5-7	5-4
Tropical regions-----	3-15	3-18	Replacement:		
Usual conditions:			Camera battery-----	5-8	5-4
Available light photography, fig. 3-13	3-8	3-11	Flashgun battery or capacitor-----	5-9	5-4
Flash photograph, fig. 3-14, 3-15,			Flashgun test lamp-----	5-10	5-4
3-16, 3-17-----	3-9	3-12	Scope-----	1-1	1-1
Infrared photography-----	3-10	3-12	Screens, focusing-----	1-15	1-5
Self-timer operation, fig. 3-18-----	3-11	3-16	Self-timer operation, fig. 3-18-----	3-11	3-16
Stopping procedures-----	3-12	3-16	Stopping procedures-----	3-12	3-16
Parts replacement-----	5-7	5-4	Technical characteristics-----	1-5	1-1
Photography:			Telephoto lens, description-----	1-10	1-3
Available light, fig. 3-13-----	3-8	3-11	Test lamp replacement, flashgun-----	5-10	5-4
Flashgun, fig. 3-14, 3-15, 3-16, 3-17 --	3-9	3-12	Tropical regions, operation-----	3-15	3-18
Infrared-----	3-10	3-12	Troubleshooting:		
Preliminary procedures:			Operator's chart-----	4-9	4-3
Changing camera lens, fig. 3-8-----	3-4	3-8	Operator's information-----	4-8	4-3
Exchanging focusing screen, fig. 3-10--	3-6	3-10	Organizational-----	5-6	5-3
Exchanging viewfinders, fig. 3-9-----	3-5	3-9	Unpacking, fig. 2-1-----	2-1	2-1
Exposure reading, fig. 3-11, 3-12-----	3-7	3-10	Use, purpose and-----	1-3	1-1
Loading film in camera, fig. 3-6, 3-7--	3-3	3-6	Visual inspection and cleaning-----	4-7	4-2
Preventive maintenance:			Weekly preventive maintenance-----	4-6	4-2
Daily-----	4-5	4-1	Wide-angle lens, description-----	1-11	1-3
Monthly-----	5-4	5-1			
Operator's-----	4-3	4-1			
Organizational-----	5-3	5-1			
Weekly-----	4-6	4-2			
Publications, indexes of-----	1-2	1-1			
Purpose and use-----	1-4	1-1			

By Order of the Secretary of the Army:

Official:

KENNETH G. WICKHAM,
*Major General, United States Army,
 The Adjutant General.*

W. C. WESTMORELAND,
*General, United States Army,
 Chief of Staff.*

Distribution:

Active Army:

USASA (2)
 CNGB (1)
 ACSC-E (2)
 Dir of Trans (1)
 Cof Engrs (1)
 TSG (1)
 CofSpts (1)
 USAARENBD (2)
 USACDC Agcy (1)
 USAMC (1)
 USCONARC (5)
 ARADCOM (5)
 ARADCOM Rgn (2)
 OS Maj Comd (4)
 LOGCOMD (2) except
 1st LOGCOMD (10)
 9th LOGCOMD (10)
 USAMICOM (4)
 USATECOM (2)
 USASTRATCOM (4)
 USAESC (70)
 MDW (1)
 Armies (2)
 Corps (2)
 1st Cav Div (5)
 Svc Colleges (2)
 USASCS (2)
 USASESS (2)
 USAADS (2)
 USAFAS (2)
 USAARMS (2)
 USAIS (2)
 USAES (2)
 USAINTS (3)
 USATC Armor (2)
 USATC Inf (2)
 USAS/TC&FG (2)
 WRAMC (1)
 Army Pic Cen (2)

USACDCEC (10)
 Instl (2) except
 Fort Gordon (10)
 Fort Huachuca (10)
 Fort Carson (25)
 Fort Knox (12)
 WSMR (5)
 Army Dep (2) except
 LBAD (14)
 SAAD (30)
 TOAD (14)
 LEAD (7)
 SHAD (3)
 NAAD (5)
 SVAD (5)
 CHAD (3)
 ATAD (10)
 Gen Deps (2)
 Sig See Gen Deps (5)
 Sig Dep (12)
 Sig FLDMS (2)
 USATOPOCOM (1)
 USAERDAA (2)
 USAERDAW (13)
 USACRREL (2)
 USAPA (3)
 MAAG (2)
 USARMIS (2)
 Units org under fol TOE:
 (2 copies each)
 11-57
 11-96
 11-97
 11-98
 11-117
 11-127
 11-158
 11-500 (AA-AC)

NG: None

USAR: None

For explanation of abbreviations used, see AR 310-50.

